

Fans and gear motors for solid fuel heating systems

Quiet and reliable output in compact design
version 2014-05

ebmpapst

The engineer's choice

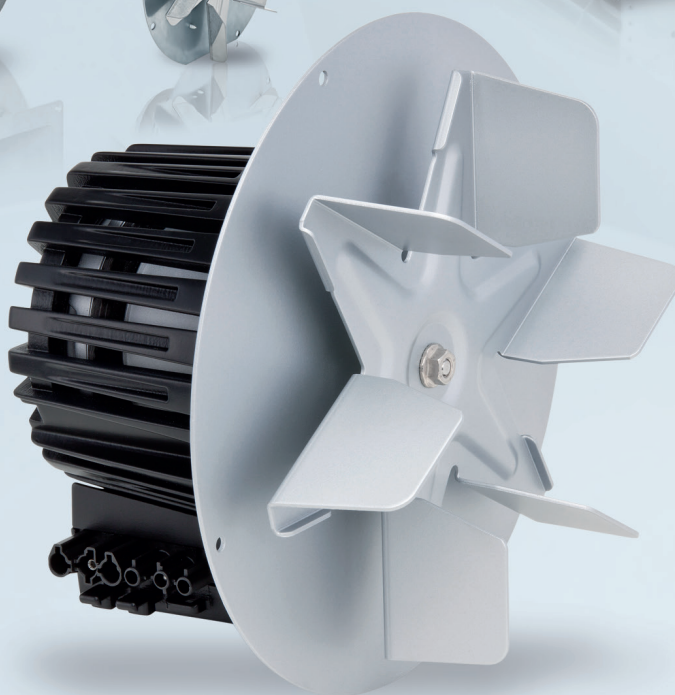
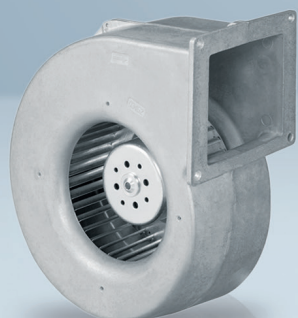

Specialists and special solutions for state-of-the-art heating engineering

Traditionally, heating engineering has been focus of the ebm-papst performance spectrum. For decades, our innovative motor and fan technology has contributed to making modern heating engineering more powerful, economical and environmentally friendly. Because we have been part of the ever-expanding solid fuel heater market for more than 15 years, we can not only rely on special fans for wood pellet heaters and wood chip ovens, but can also integrate exceptional application skills and knowledge.

With fan technology specially developed for the requirements of wood pellet heaters and wood chip ovens, our goal is to provide the required air flow for all systems – whether their heating capacity is 5 kW or 200 kW, and for every conceivable operating state – and to do so quietly and economically. Even today, we offer a range of fan products tailored to the widely varying oven sizes in tried-and-tested AC & EC technology: fans for both intake and exhaust air.

We gladly take advantage of opportunities to integrate our application skills and knowledge, as well as our experience in high-temperature applications, into the development of new devices and systems at an early stage. One of the ways we help is to make our measurement laboratory available to our customers so that they can optimize specific application designs in the ovens. This guarantees the best possible fulfillment of the stringent requirements for temperature stability and noise with fan technology that is perfectly suited to the application.

High performance in a small space

The tight space of the ovens is another challenge we constantly strive to master. Every application should embody the ideal combination of size, output and cost-effectiveness. Our highly compact fan motors, with their external rotor design, offer the best possible conditions. The design differs from that of conventional electric motors – the stator is inside, the rotor outside. Thus the external rotor-motor and the fan form a unit that is not only compact and space-saving, but also durable and robust.



Table of contents

Specialists and special solutions for state-of-the-art heating engineering	2	Scroll dimensions	92
GreenTech: The Green Company	4	Additional shaft seal	94
The entire product range from a single source	6	Electrical connections	94
EC/AC centrifugal blowers (intake air)	9	Technical parameters & scope	100
EC/AC centrifugal blowers (ambient air)	26	ebm-papst representatives & subsidiaries	104
EC/AC tangential blowers (ambient air)	32		
EC/AC centrifugal fans (exhaust air)	37		
EC/AC centrifugal blowers (exhaust air)	71		
Gear motors	83		

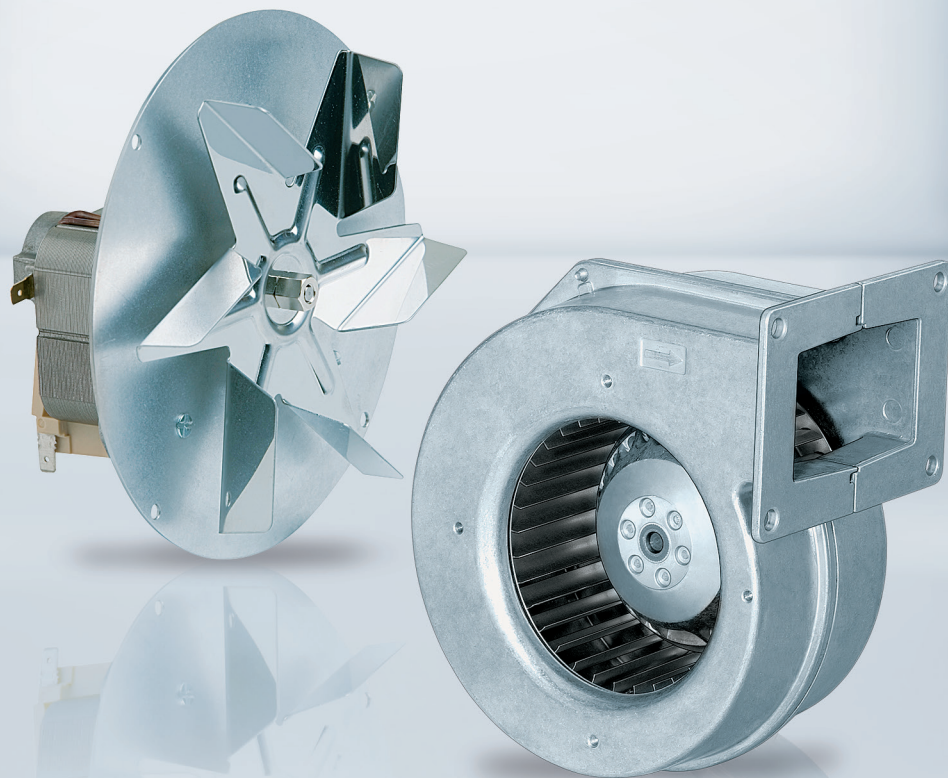

Sustainability is at the centre of our thoughts and actions. Out of conviction!

Eco-friendliness and sustainability have always been at the core of our thoughts and actions. For decades, we have worked according to the simple but strict creed of our co-founder Gerhard Sturm: “Each new product we develop has to be better than the last one in terms of economy and ecology.” GreenTech is the ultimate expression of our corporate philosophy.

GreenTech is pro-active development.

Even in the design phase, the materials and processes we use are optimised for the greatest possible eco-friendliness, energy balance and – wherever possible – recyclability. We continually improve the material and performance of our products, as well as the flow and noise characteristics. At the same time, we significantly reduce energy consumption. Close co-operation with universities and scientific institutes and the professorship we endow in the area of power engineering and regenerative energies allows us to profit from the latest research findings in these fields – and at the same time ensure highly qualified young academics.

GreenTech is eco-friendly production.

GreenTech also stands for maximum energy efficiency in our production processes. There, the intelligent use of industrial waste heat and groundwater cooling, photovoltaics and, of course, our own cooling and ventilation technology are of the utmost importance. Our most modern plant, for instance, consumes 91% less energy than currently specified and required. In this way, our products contribute to protecting the environment, from their origin to their recyclable packaging.

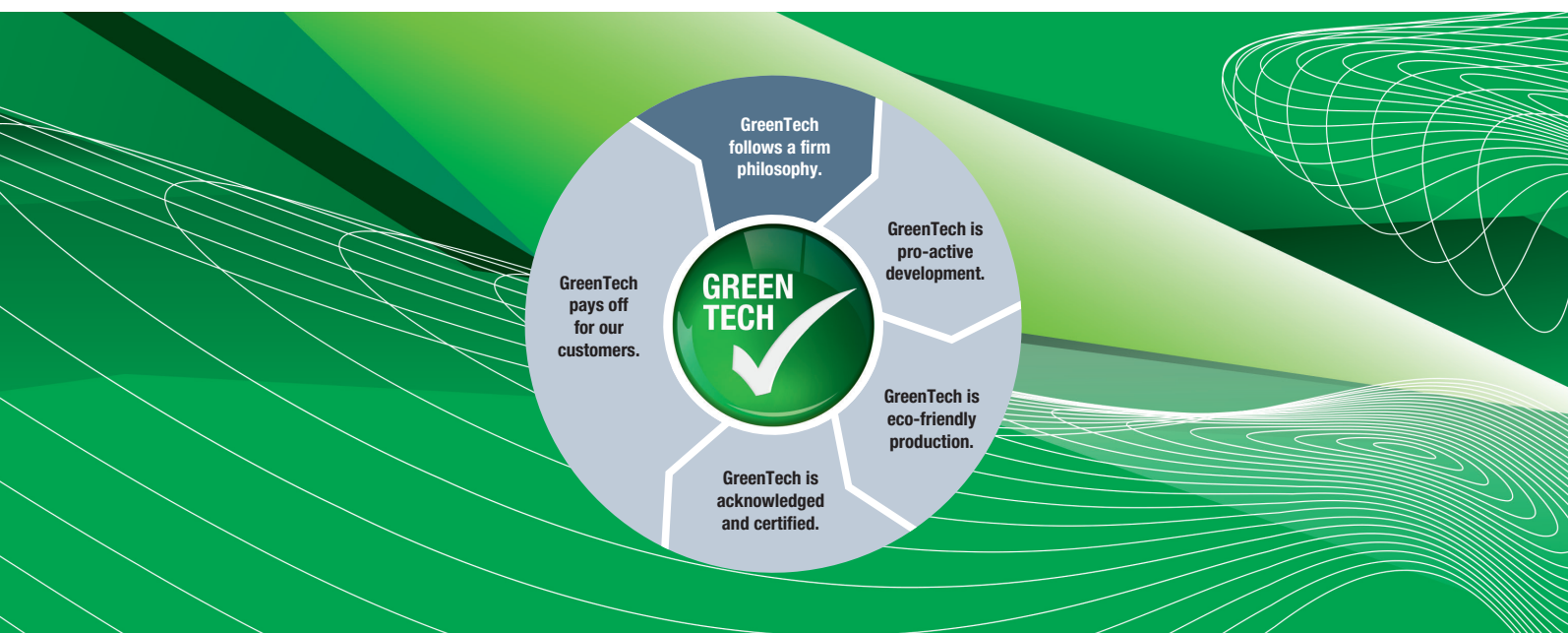

GreenTech is acknowledged and certified.

Every step in our chain of production meets the stringent standards of environmental specialists and the public.

This supports our position as Germany's most sustainable company 2013, as does the DEKRA Award 2012 we received in the category "Umwelt – Herausforderung Energiewende / Environment – Challenge: Transition to more sustainable energy systems", to name only a few of a large number of examples. The environmental advantage gained in the performance of the products developed from our GreenTech philosophy can also be measured in the fulfillment of the most stringent energy and environmental standards. In many instances, our products are already well below the thresholds energy legislation will impose a few years from now – several times over.

Our customers profit from this every day.

The heart of GreenTech is future-oriented EC technology from ebmpapst. The EC technology at the core of our most efficient motors and fans allows efficiency of up to 90%, saves energy at a very high level, significantly extends service life and makes our products maintenance-free. These values pay off not only for the environment, but every cent also pays off for the user! All ebmpapst products – even those for which GreenTech EC technology does not (yet) make sense from an application viewpoint – feature the greatest possible connection of economy and ecology.



GreenTech means
ecologically improving
every new product.

The entire product range from a single source

Fans for intake air

Used as primary or secondary intake air fans, ebm-papst AC & EC centrifugal blowers shine with their quiet and economical performance. The blowers can be equipped with an optional tach output for exact control according to the operating mode.

Of course, ebm-papst products always designed for an uncompromising level of stability and durability. For example, the scroll housing of the ebm-papst centrifugal blower is made of robust die-cast aluminium, and the impeller is made of hot-galvanized sheet steel.

Fans for ambient air

Fans for air circulation are sometimes employed in pellet stoves to ensure uniform distribution of the heated air throughout the room. Use is made of tangential blowers or forward-curved blowers for this purpose.

Fans for exhaust air

Exhaust air is carried away by ebm-papst induced draft blowers: single inlet AC centrifugal fans. With our extensive experience in high-temperature bearing technology and the aerodynamic skills and knowledge gained from being the market leader, we can meet the most stringent demands of this application area for service life, noise and cost-effectiveness.

The type of construction itself guarantees exceptional cooling performance – which is improved even further by the flow-optimized cooling blades that provide additional motor cooling. The impellers of our centrifugal fans are made of corrosion-resistant stainless steel.

Gear motors

A worm conveyor moves the pellets into the combustion chamber of the stove. Precise metering of the pellets is crucial to obtain the required heat output. This is achieved by using special gear motors from ebm-papst.



Solid fuel heater manufacturers can count on ebm-papst for complete solutions from a single source. Our product range for wood pellet heaters and wood chip ovens includes intake air fans and customized exhaust air fans for exhaust gas discharge.

Example for a central heating unit:

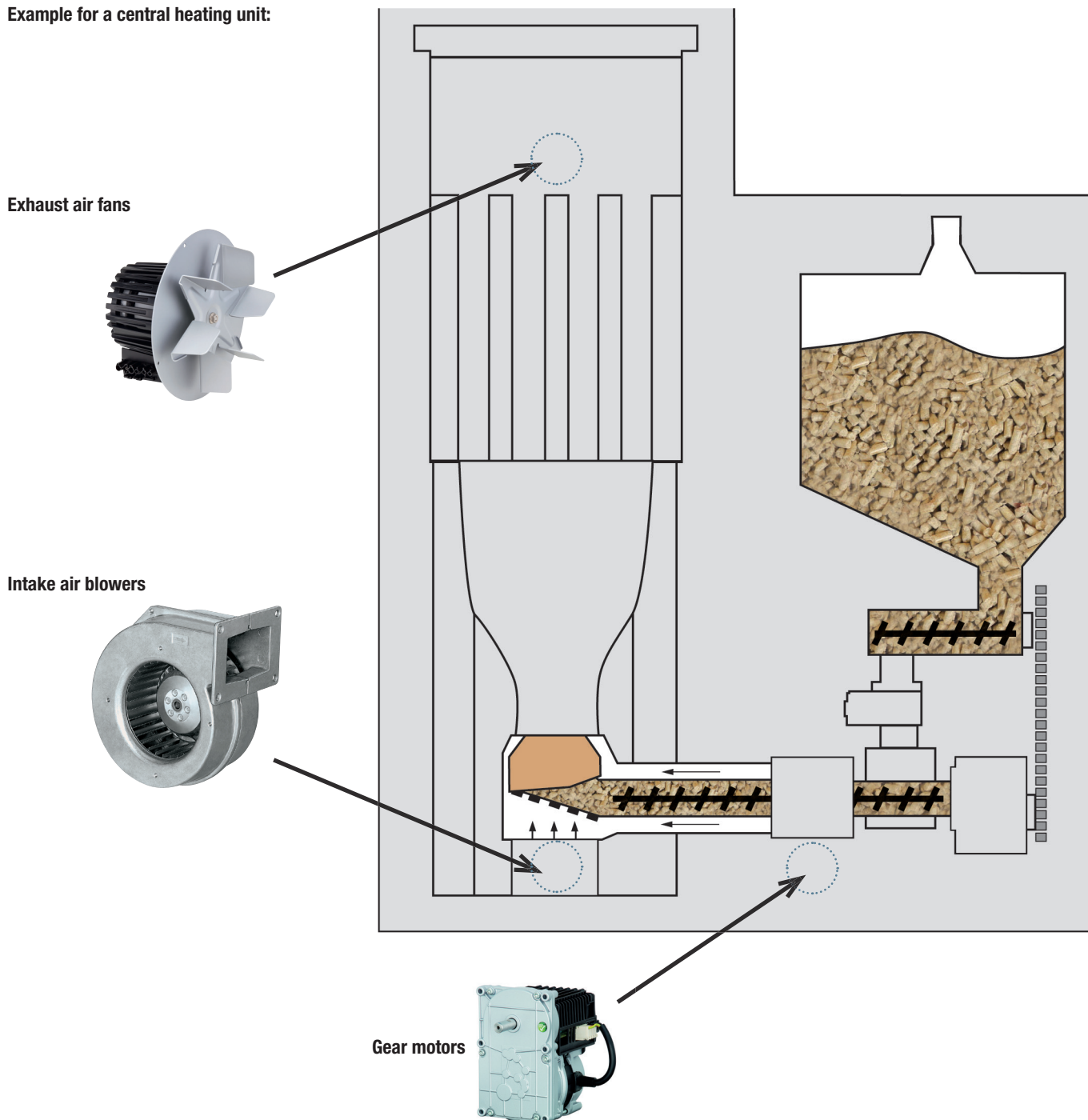



EC/AC centrifugal blowers (intake air)



EC centrifugal blowers (intake air)

for solid fuel heating systems, single inlet, Ø 108



- **Material:** Housing: Die-cast aluminium
Impeller: Hot-dip galvanised sheet steel
Rotor: Galvanised
Electronics enclosure: Die-cast aluminium
- **Direction of rotation:** Clockwise, seen on rotor
- **Type of protection:** IP 44
- **Insulation class:** "B"
- **Mounting position:** Any
- **Condensate discharges:** None
- **Mode of operation:** Continuous operation (S1)
- **Bearings:** Maintenance-free ball bearings

Nominal data		Curve	Nominal voltage	Frequency	Air flow	Speed/rpm ⁽¹⁾	Max. input power ⁽¹⁾	Max. current draw ⁽¹⁾	Sound pressure level	Min. back pressure	Perm. amb. temp.	Mass	Electr. connection
Type	Motor	VAC	Hz	m ³ /h	rpm	W	A	dB(A)	Pa	°C	kg	p. 95	
G3G 108-BB01 -02	M3G 055-BD	Ⓐ 1~230	50/60	244	2800	50	0,38	64	0	-25..+60	1,7	H1)	

subject to alterations (1) Nominal data in operating point with maximum load and 230 VAC

Curves:

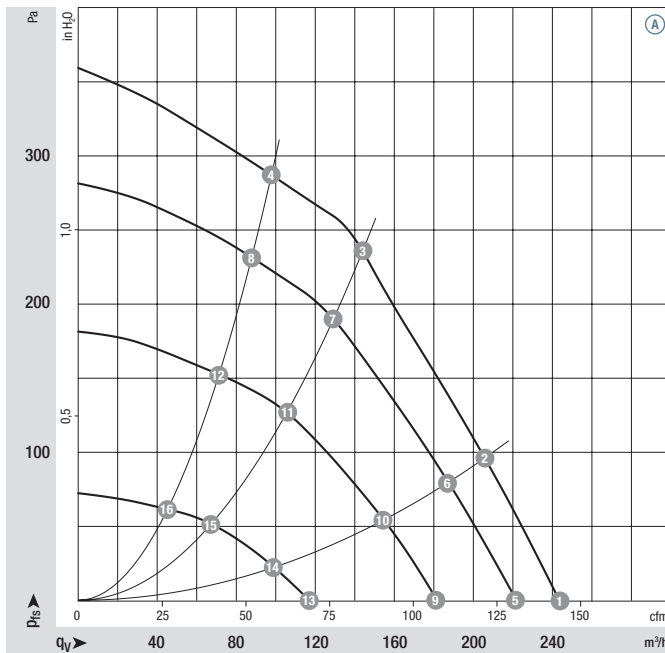

	n rpm	P _{ed} W	I A	L _{pA} dB(A)
Ⓐ 1	2800	50	0,38	64
Ⓐ 2	2950	44	0,35	62
Ⓐ 3	3120	33	0,25	60
Ⓐ 4	3260	25	0,20	59
Ⓐ 5	2570	38	0,30	61
Ⓐ 6	2660	34	0,25	60
Ⓐ 7	2820	25	0,20	57
Ⓐ 8	2920	19	0,15	55
Ⓐ 9	2150	23	0,20	56
Ⓐ 10	2200	20	0,15	55
Ⓐ 11	2320	16	0,15	52
Ⓐ 12	2390	12	0,10	50
Ⓐ 13	1400	9	0,10	46
Ⓐ 14	1425	8	0,10	44
Ⓐ 15	1490	7	0,10	40
Ⓐ 16	1530	6	0,10	40

Air performance measured as per: ISO 5801, Installation category A, with ebm-papst scroll housing without protection against accidental contact. Suction-side noise levels: L_{WA} as per ISO 13347, L_{pA} measured at 1 m distance to fan axis. The acoustic values given are only valid under the measurement conditions listed and may vary depending on the installation situation. With any deviation to the standard setup, the specific values have to be checked and reviewed once installed or fitted! For detailed information see page 100 ff.

- **Technical features:**
 - Control input 0-10 VDC / PWM
 - Output 10 VDC max. 1,1 mA
 - Tach output
 - Locked-rotor protection
- **EMC:** Interference emission acc. EN 61000-6-3
Interference immunity acc. EN 61000-6-1
Harmonics acc. EN 61000-3-2/3
- **Touch current:** < 3,5 mA acc. to IEC 60990 (test circuit, illustration 4)
- **Cable exit:** Variable
- **Protection class:** I
- **Product conforming to standards:** EN 60335-1, CE
- **Approvals:** CCC, GOST; VDE, UL, CSA are applied for

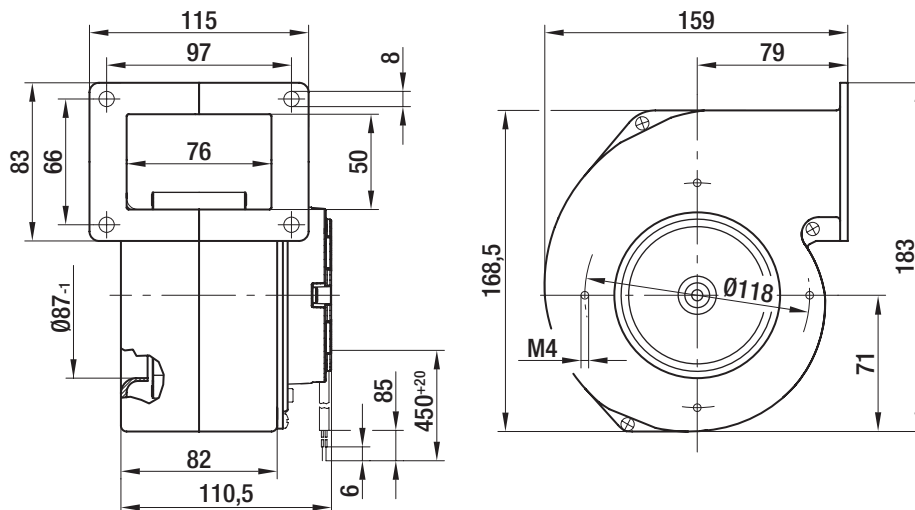

EC centrifugal blowers (intake air)

for solid fuel heating systems, single inlet, Ø 120

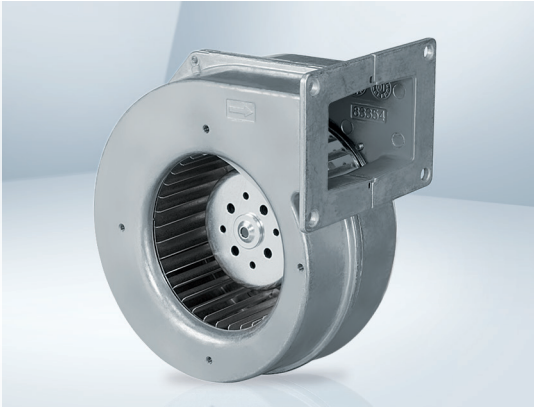

- **Material:** Housing: Die-cast aluminium
Impeller: Hot-dip galvanised sheet steel
Rotor: Galvanised
Electronics enclosure: Die-cast aluminium
- **Direction of rotation:** Clockwise, seen on rotor
- **Type of protection:** IP 44
- **Insulation class:** "B"
- **Mounting position:** Any
- **Condensate discharges:** None
- **Mode of operation:** Continuous operation (S1)
- **Bearings:** Maintenance-free ball bearings

Nominal data		Curve	Nominal voltage	Frequency	Air flow	Speed/rpm ⁽¹⁾	Max. input power ⁽¹⁾	Max. current draw ⁽¹⁾	Sound pressure level	Min. back pressure	Perm. amb. temp.	Mass	Electr. connection
Type	Motor	VAC	Hz	m ³ /h	rpm	W	A	dB(A)	Pa	°C	kg	p. 95	
G3G 120-BB03 -02	M3G 055-BD	Ⓐ 1~230	50/60	240	2200	41	0,30	61	0	-25..+60	1,8	H1)	

subject to alterations (1) Nominal data in operating point with maximum load and 230 VAC

Curves:

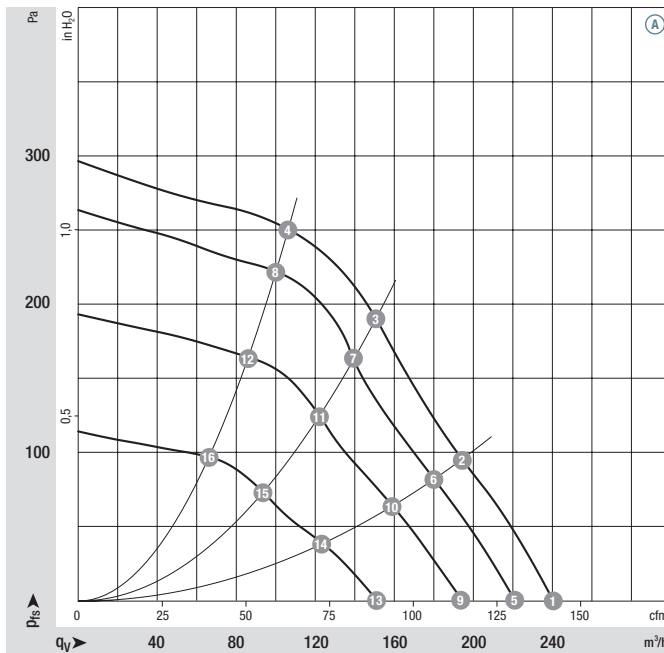

	n rpm	P _{ed} W	I A	L _{pA} dB(A)
Ⓐ 1	2200	41	0,30	61
Ⓐ 2	2320	34	0,25	60
Ⓐ 3	2440	28	0,20	59
Ⓐ 4	2600	20	0,15	58
Ⓐ 5	2060	34	0,25	59
Ⓐ 6	2190	29	0,20	57
Ⓐ 7	2295	24	0,20	55
Ⓐ 8	2445	18	0,15	54
Ⓐ 9	1830	24	0,20	54
Ⓐ 10	1920	20	0,15	52
Ⓐ 11	2010	17	0,15	51
Ⓐ 12	2115	13	0,10	51
Ⓐ 13	1430	13	0,10	48
Ⓐ 14	1500	12	0,10	45
Ⓐ 15	1580	10	0,10	44
Ⓐ 16	1640	8	0,10	44

Air performance measured as per: ISO 5801, Installation category A, with ebm-papst scroll housing without protection against accidental contact. Suction-side noise levels: L_{wa} as per ISO 13347, L_{pA} measured at 1 m distance to fan axis. The acoustic values given are only valid under the measurement conditions listed and may vary depending on the installation situation. With any deviation to the standard setup, the specific values have to be checked and reviewed once installed or fitted! For detailed information see page 100 ff.

- **Technical features:**
 - Control input 0-10 VDC / PWM
 - Output 10 VDC max. 1,1 mA
 - Tach output
 - Locked-rotor protection
- **EMC:** Interference emission acc. EN 61000-6-3
Interference immunity acc. EN 61000-6-1
Harmonics acc. EN 61000-3-2/3
- **Touch current:** < 3,5 mA acc. to IEC 60990 (test circuit, illustration 4)
- **Cable exit:** Variable
- **Protection class:** I
- **Product conforming to standards:** EN 60335-1, CE
- **Approvals:** GOST; VDE, UL, CSA, CCC are applied for

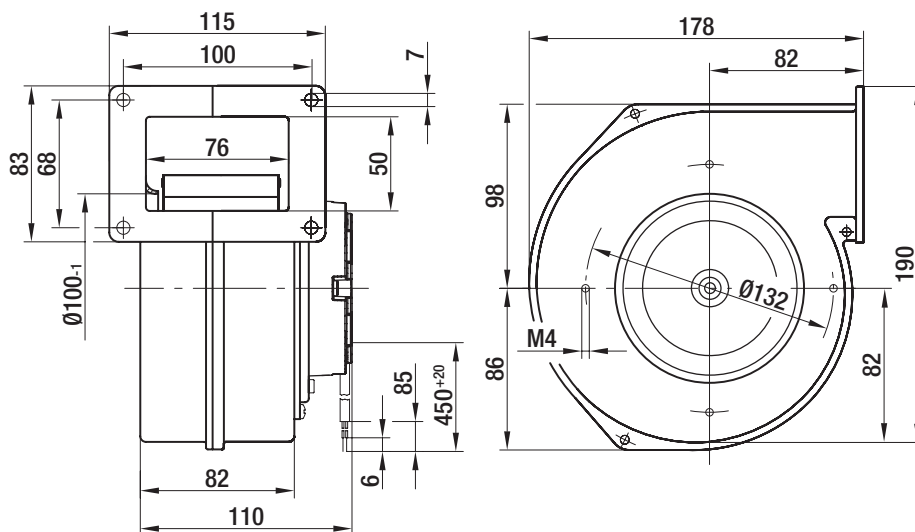

EC centrifugal blowers (intake air)

for solid fuel heating systems, single inlet, Ø 140

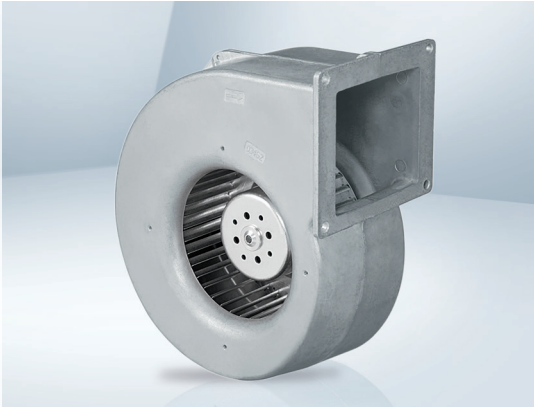

- **Material:** Housing: Die-cast aluminium
Impeller: Hot-dip galvanised sheet steel
Rotor: Galvanised
Electronics enclosure: Die-cast aluminium
- **Direction of rotation:** Clockwise, seen on rotor
- **Type of protection:** IP 44
- **Insulation class:** "B"
- **Mounting position:** Any
- **Condensate discharges:** None
- **Mode of operation:** Continuous operation (S1)
- **Bearings:** Maintenance-free ball bearings

Nominal data		Curve	Nominal voltage	Frequency	Air flow	Speed/rpm ⁽¹⁾	Max. input power ⁽¹⁾	Max. current draw ⁽¹⁾	Sound pressure level	Min. back pressure	Perm. amb. temp.	Mass	Electr. connection
Type	Motor	VAC	Hz	m ³ /h	rpm	W	A	dB(A)	Pa	°C	kg	p. 95	
G3G 140-AV03 -02	M3G 055-CF	Ⓐ 1~230	50/60	425	1800	66	0,50	63	0	-25..+60	2,6	H1)	

subject to alterations (1) Nominal data in operating point with maximum load and 230 VAC

Curves:

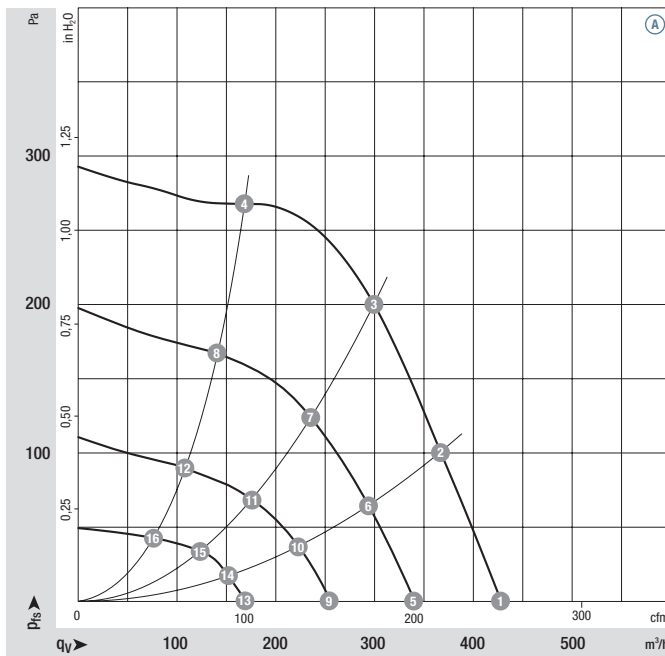

	n rpm	P _{ed} W	I A	L _{pA} dB(A)
Ⓐ 1	1800	66	0,50	63
Ⓐ 2	1860	58	0,40	61
Ⓐ 3	1970	49	0,35	59
Ⓐ 4	2170	33	0,25	58
Ⓐ 5	1410	33	0,30	58
Ⓐ 6	1500	30	0,25	56
Ⓐ 7	1600	25	0,25	54
Ⓐ 8	1790	18	0,15	53
Ⓐ 9	1060	14	0,15	51
Ⓐ 10	1105	13	0,15	50
Ⓐ 11	1210	11	0,15	47
Ⓐ 12	1355	8	0,10	47
Ⓐ 13	705	4	0,10	40
Ⓐ 14	750	4	0,10	39
Ⓐ 15	800	3	0,10	38
Ⓐ 16	895	3	0,10	37

Air performance measured as per: ISO 5801, Installation category A, with ebm-papst scroll housing without protection against accidental contact. Suction-side noise levels: L_{WA} as per ISO 13347, L_{pA} measured at 1 m distance to fan axis. The acoustic values given are only valid under the measurement conditions listed and may vary depending on the installation situation. With any deviation to the standard setup, the specific values have to be checked and reviewed once installed or fitted! For detailed information see page 100 ff.

- **Technical features:**
 - Control input 0-10 VDC / PWM
 - Output 10 VDC max. 1,1 mA
 - Tach output
 - Locked-rotor protection
- **EMC:** Interference emission acc. EN 61000-6-3
Interference immunity acc. EN 61000-6-1
Harmonics acc. EN 61000-3-2/3
- **Touch current:** < 3,5 mA acc. to IEC 60990 (test circuit, illustration 4)
- **Cable exit:** Variable
- **Protection class:** I
- **Product conforming to standards:** EN 60335-1, CE
- **Approvals:** CCC, GOST; VDE, UL, CSA are applied for

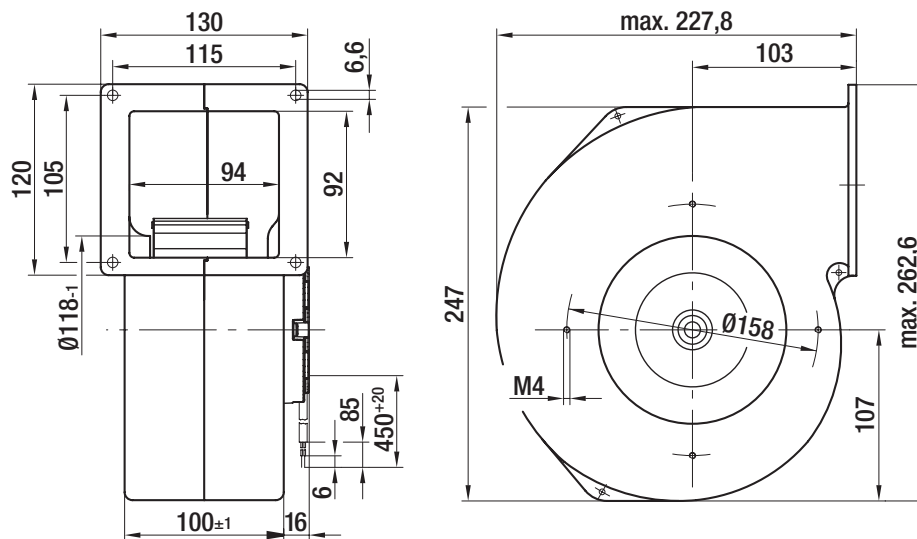

EC centrifugal blowers (intake air)

for solid fuel heating systems, single inlet, Ø 160



- **Material:** Housing: Die-cast aluminium
Impeller: Galvanised sheet steel
Rotor: Coated in black
Electronics enclosure: Die-cast aluminium
- **Direction of rotation:** Clockwise, seen on rotor
- **Type of protection:** IP 44
- **Insulation class:** "B"
- **Mounting position:** Shaft horizontal or rotor on top, rotor on bottom on request
- **Condensate discharges:** None
- **Mode of operation:** Continuous operation (S1)
- **Bearings:** Maintenance-free ball bearings

Nominal data		Curve	Nominal voltage range	Frequency	Air flow	Speed/rpm ⁽¹⁾	Max. input power ⁽¹⁾	Max. current draw ⁽¹⁾	Sound pressure level	Min. back pressure	Perm. amb. temp.	Mass	Electr. connection
Type	Motor	VAC	Hz	m ³ /h	rpm	W	A	dB(A)	Pa	°C	kg	p. 95	
G3G 160-AC50 -01	M3G 074-CF	(A) 1~200-277	50/60	630	2150	170	1,25	72	0	-25..+60	3,5	H1)	

subject to alterations (1) Nominal data in operating point with maximum load and 230 VAC

Curves:

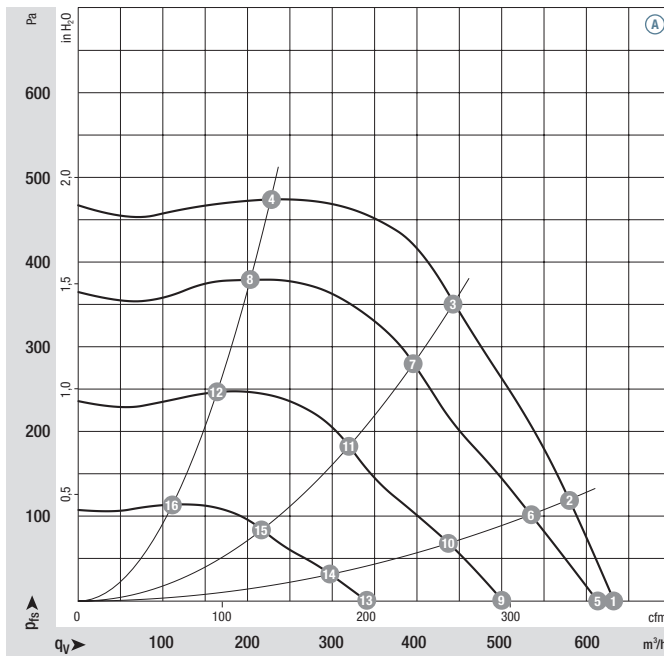

	n rpm	P _{ed} W	I A	L _{pA} dB(A)
(A) 1	2150	170	1,25	72
(A) 2	2310	170	1,25	71
(A) 3	2450	139	1,10	70
(A) 4	2540	91	0,70	68
(A) 5	2070	153	1,10	69
(A) 6	2090	138	1,00	67
(A) 7	2150	101	0,80	65
(A) 8	2205	68	0,60	63
(A) 9	1700	91	0,70	63
(A) 10	1730	80	0,60	62
(A) 11	1760	60	0,50	59
(A) 12	1795	41	0,30	58
(A) 13	1190	37	0,30	54
(A) 14	1200	33	0,30	53
(A) 15	1220	27	0,25	51
(A) 16	1240	20	0,20	48

Air performance measured as per: ISO 5801, Installation category A, with ebm-papst scroll housing without protection against accidental contact. Suction-side noise levels: L_{WA} as per ISO 13347, L_{pA} measured at 1 m distance to fan axis. The acoustic values given are only valid under the measurement conditions listed and may vary depending on the installation situation. With any deviation to the standard setup, the specific values have to be checked and reviewed once installed or fitted! For detailed information see page 100 ff.

- **Technical features:**
 - PFC (passive)
 - Control input 0-10 VDC / PWM
 - Output 10 VDC max. 1,1 mA
 - Tach output
 - Over-temperature protected electronics / motor
- **EMC:** Interference emission acc. EN 61000-6-3
Interference immunity acc. EN 61000-6-1
Harmonics acc. EN 61000-3-2/3
- **Touch current:** < 3,5 mA acc. to IEC 60990 (test circuit, illustration 4)
- **Cable exit:** Variable
- **Protection class:** I
- **Product conforming to standards:** EN 60335-1, EN 61800-5-1, EN 60950-1, CE
- **Approvals:** UL, CSA, CCC; GOST is applied for

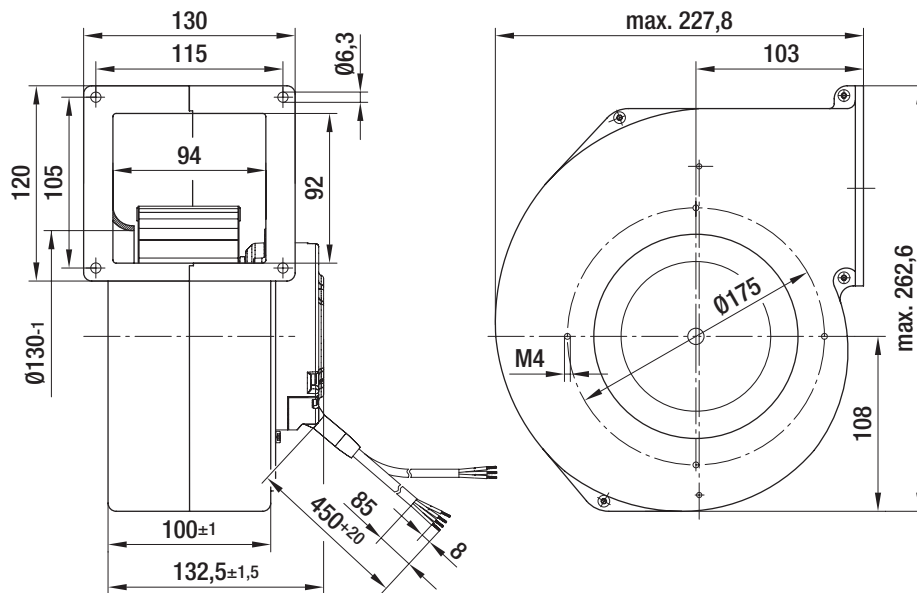

AC centrifugal blowers (intake air)

for solid fuel heating systems, single inlet, Ø 108



- **Material:** Housing: Die-cast aluminium
Impeller: Galvanised sheet steel
Rotor: Partially cast in aluminium
- **Direction of rotation:** Clockwise, seen on rotor
- **Type of protection:** IP 44
- **Insulation class:** "B"
- **Mounting position:** Any
- **Condensate discharges:** None
- **Mode of operation:** Continuous operation (S1)
- **Bearings:** Maintenance-free ball bearings

Nominal data		Curve	Nominal voltage	Frequency	Air flow	Speed/rpm	Input power	Current draw	Capacitor	Sound pressure level	Min. back pressure	Perm. amb. temp.	Mass	Electr. connection
Type	Motor	VAC	Hz	m ³ /h	rpm	W	A	µF/VDB	dB(A)	Pa	°C	kg	p. 98	
G2E 108-AG63 -01	M2E 052-BF	Ⓐ	230	50	160	1850	30	0,14	1,0/400	56	0	-25..+85	1,3	A1)

subject to alterations

Curves:

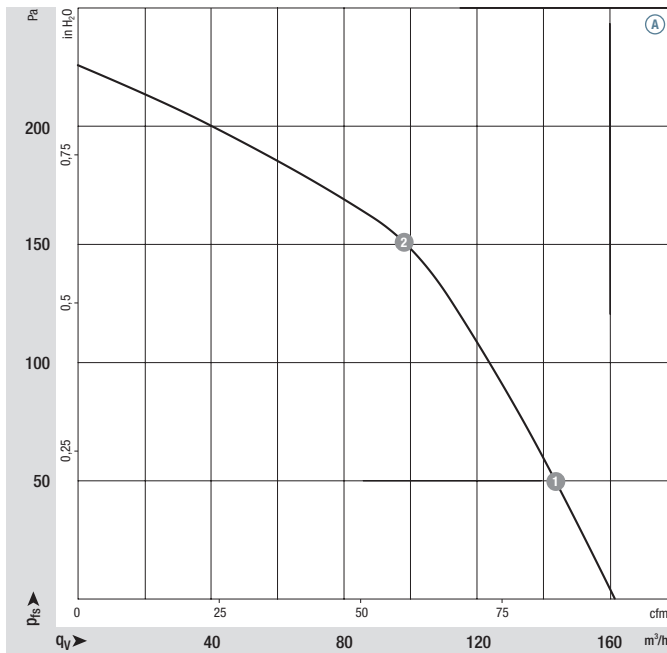

	n rpm	P _{ed} W	I A	L _{pA} dB(A)
Ⓐ 1	2050	28	0,12	56
Ⓐ 2	2400	24	0,11	54

Air performance measured as per: ISO 5801, Installation category A, with ebm-papst scroll housing without protection against accidental contact. Suction-side noise levels: L_w as per ISO 13347, L_{pA} measured at 1 m distance to fan axis. The acoustic values given are only valid under the measurement conditions listed and may vary depending on the installation situation. With any deviation to the standard setup, the specific values have to be checked and reviewed once installed or fitted! For detailed information see page 100 ff.

- **Motor protection:** TOP wired internally
- **Touch current:** < 0,75 mA acc. to IEC 60990 (test circuit, illustration 4)
- **Cable exit:** Variable
- **Protection class:** I
- **Product conforming to standards:** EN 60335-1, CE
- **Approvals:** CCC

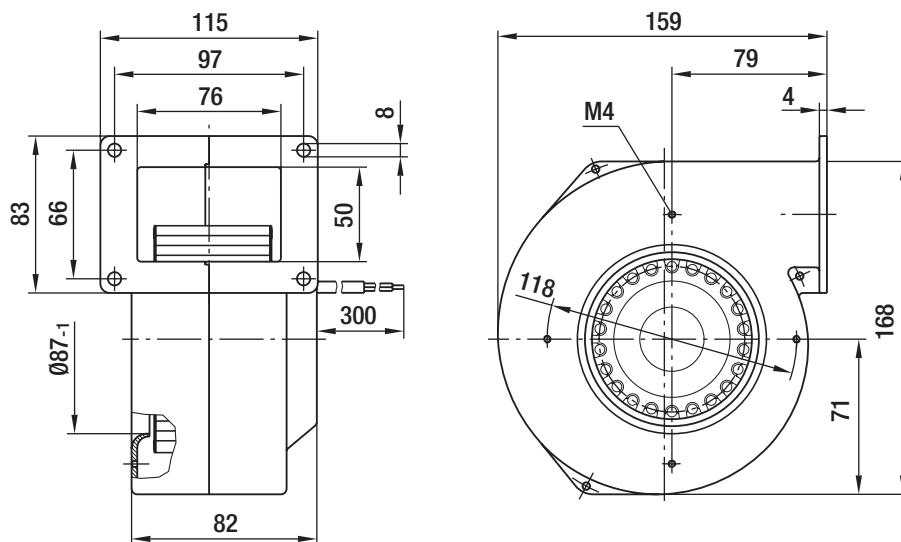

AC centrifugal blowers (intake air)

for solid fuel heating systems, single inlet, Ø 120

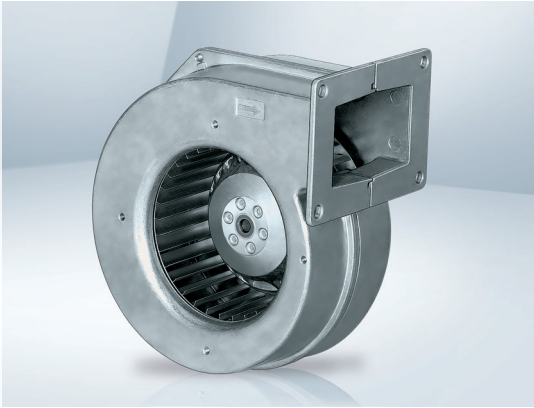

- **Material:** Housing: Die-cast aluminium
Impeller: Galvanised sheet steel
Rotor: Partially cast in aluminium
- **Direction of rotation:** Clockwise, seen on rotor
- **Type of protection:** IP 44
- **Insulation class:** "B"
- **Mounting position:** Any
- **Condensate discharges:** None
- **Mode of operation:** Continuous operation (S1)
- **Bearings:** Maintenance-free ball bearings

Nominal data		Curve	Nominal voltage	Frequency	Air flow	Speed/rpm	Input power	Current draw	Capacitor	Sound pressure level	Min. back pressure	Perm. amb. temp.	Mass	Electr. connection
Type	Motor	VAC	Hz	m ³ /h	rpm	W	A	µF/VDB	dB(A)	Pa	°C	kg	p. 98	
G2E 120-AR77 -01	M2E 068-BF	Ⓐ	230	50	255	2350	80	0,35	2,0/450	61	0	-25..+55	1,8	A1)

subject to alterations

Curves:

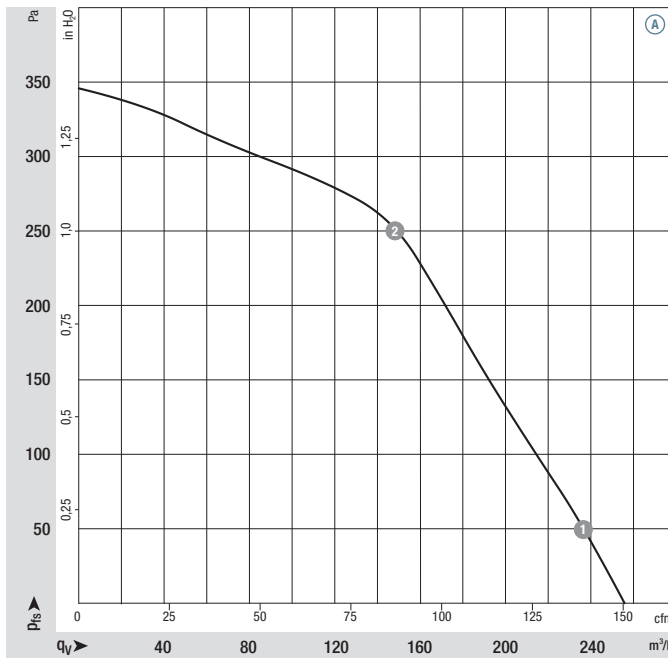

	n rpm	P _{ed} W	I A	L _{pA} dB(A)
Ⓐ 1	2460	77	0,34	60
Ⓐ 2	2665	69	0,31	56

Air performance measured as per: ISO 5801, Installation category A, with ebm-papst scroll housing without protection against accidental contact. Suction-side noise levels: L_w as per ISO 13347, L_{pA} measured at 1 m distance to fan axis. The acoustic values given are only valid under the measurement conditions listed and may vary depending on the installation situation. With any deviation to the standard setup, the specific values have to be checked and reviewed once installed or fitted! For detailed information see page 100 ff.

- **Motor protection:** TOP wired internally
- **Touch current:** < 0,75 mA acc. to IEC 60990 (test circuit, illustration 4)
- **Optional:** Speed monitoring via Hall IC
- **Cable exit:** Variable
- **Protection class:** I
- **Product conforming to standards:** EN 60335-1, CE
- **Approvals:** CCC; GOST is applied for

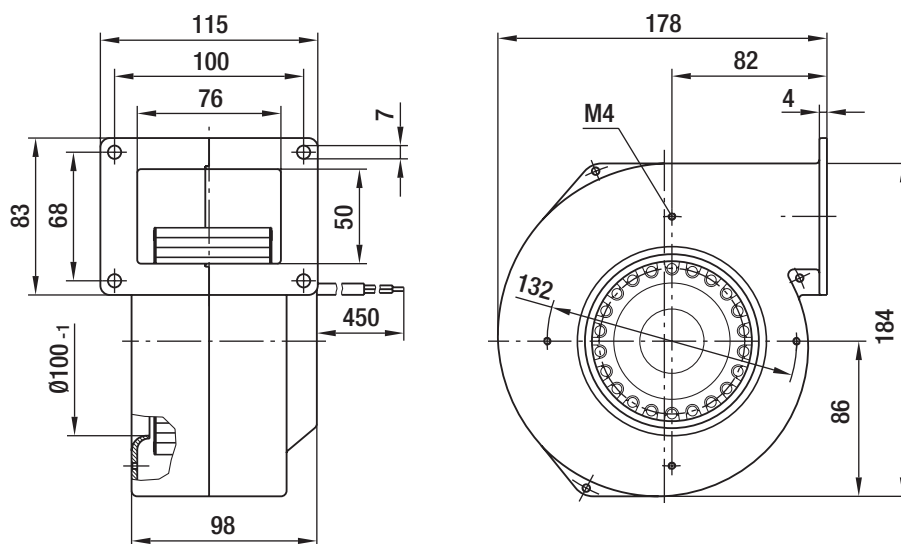

AC centrifugal blowers (intake air)

for solid fuel heating systems, single inlet, Ø 140

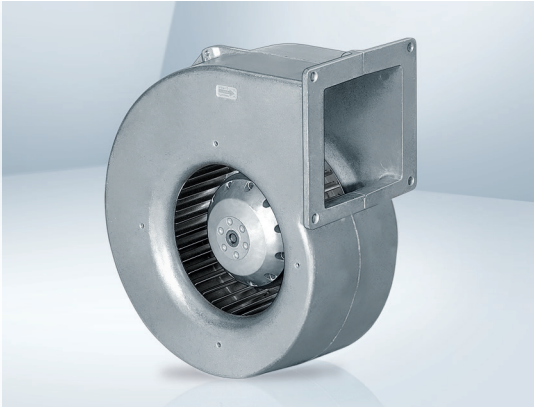

- **Material:** Housing: Die-cast aluminium
Impeller: Galvanised sheet steel
Rotor: Partially cast in aluminium
- **Direction of rotation:** Clockwise, seen on rotor
- **Type of protection:** IP 44
- **Insulation class:** "B"
- **Mounting position:** Any
- **Condensate discharges:** None
- **Mode of operation:** Continuous operation (S1)
- **Bearings:** Maintenance-free ball bearings

Nominal data		Curve	Nominal voltage	Frequency	Air flow	Speed/rpm	Input power	Current draw	Capacitor	Sound pressure level	Min. back pressure	Perm. amb. temp.	Mass	Electr. connection
Type	Motor	VAC	Hz	m ³ /h	rpm	W	A	µF/VDB	dB(A)	Pa	°C	kg	p. 98	
G2E 140-AL40 -01	M2E 068-CF	Ⓐ 1~230 1~230	50 60	415 340	1650 1700	135 145	0,60 0,64	2,0/450 2,0/450	63 60	0 100	-25..+60 -25..+40	3,0 3,0	A1)	

subject to alterations

Curves:

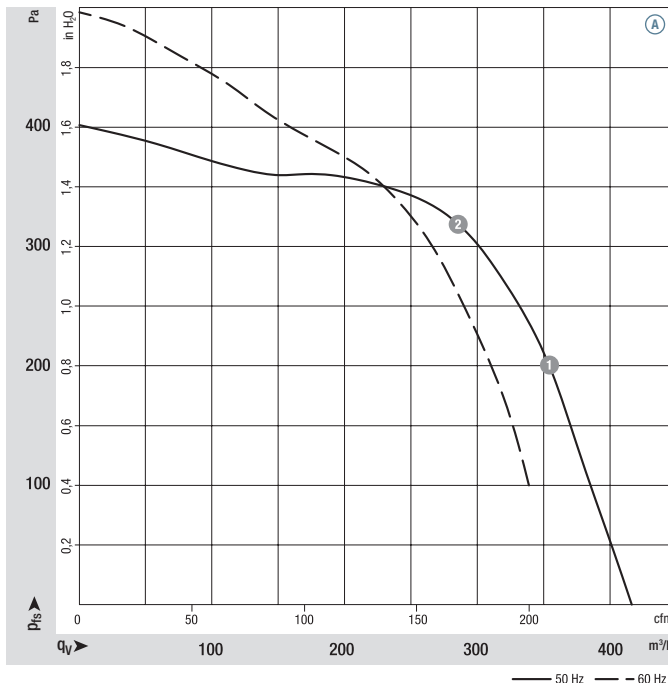

	n rpm	P _{ed} W	I A	L _{pA} dB(A)
Ⓐ 1	2100	111	0,48	62
Ⓐ 2	2350	98	0,43	62

Air performance measured as per: ISO 5801, Installation category A, with ebm-papst scroll housing without protection against accidental contact. Suction-side noise levels: L_w as per ISO 13347, L_{pA} measured at 1 m distance to fan axis. The acoustic values given are only valid under the measurement conditions listed and may vary depending on the installation situation. With any deviation to the standard setup, the specific values have to be checked and reviewed once installed or fitted! For detailed information see page 100 ff.

- **Motor protection:** TOP wired internally
- **Touch current:** < 0,75 mA acc. to IEC 60990 (test circuit, illustration 4)
- **Optional:** Speed monitoring via Hall IC
- **Cable exit:** Variable
- **Protection class:** I
- **Product conforming to standards:** EN 60335-1, CE
- **Approvals:** CCC; GOST is applied for

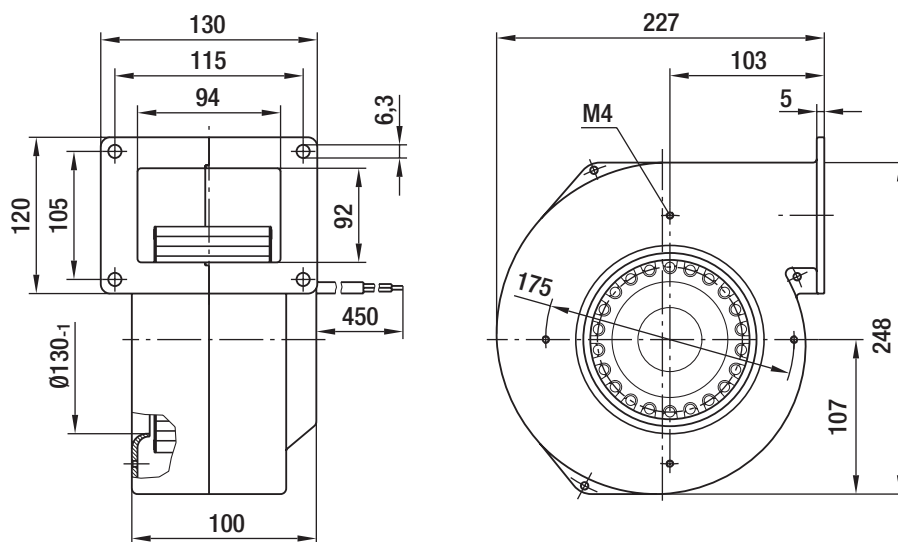

AC centrifugal blowers (intake air)

for solid fuel heating systems, single inlet, Ø 160



- **Material:** Housing: Die-cast aluminium
Impeller: Galvanised sheet steel
Rotor: Partially cast in aluminium
- **Direction of rotation:** Clockwise, seen on rotor
- **Type of protection:** IP 44
- **Insulation class:** "B"
- **Mounting position:** Any
- **Condensate discharges:** None
- **Mode of operation:** Continuous operation (S1)
- **Bearings:** Maintenance-free ball bearings

Nominal data		Curve	Nominal voltage	Frequency	Air flow	Speed/rpm	Input power	Current draw	Capacitor	Sound pressure level	Min. back pressure	Perm. amb. temp.	Mass	Electr. connection
Type	Motor	VAC	Hz	m ³ /h	rpm	W	A	µF/VDB	dB(A)	Pa	°C	kg	p. 98	
G2E 160-AY50 -91	M2E 068-EC	Ⓐ	230	50	600	2280	270	1,18	6,0/400	72	100	-25..+60	4,2	A1)

subject to alterations

Curves:

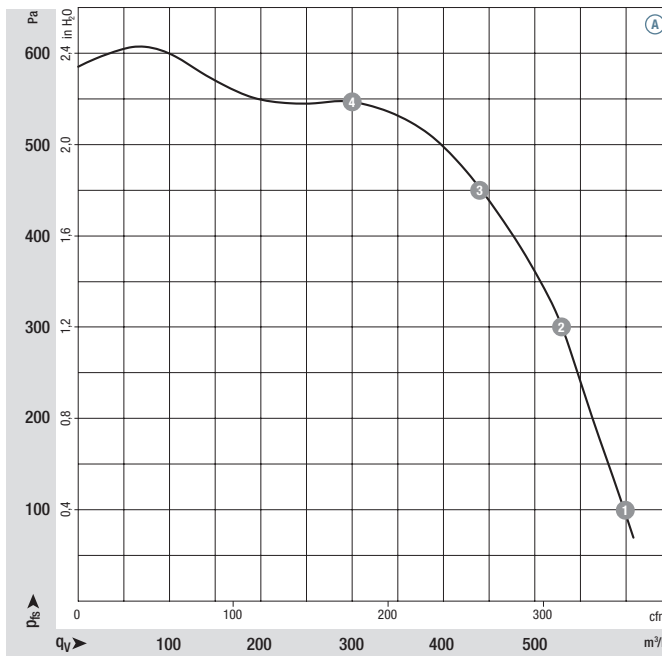

	n rpm	P _{ed} W	I A	L _{pA} dB(A)
Ⓐ 1	2280	270	1,18	72
Ⓐ 2	2480	227	0,98	70
Ⓐ 3	2620	192	0,83	68
Ⓐ 4	2750	152	0,66	67

Air performance measured as per: ISO 5801, Installation category A, with ebm-papst scroll housing without protection against accidental contact. Suction-side noise levels: L_w as per ISO 13347, L_{pA} measured at 1 m distance to fan axis. The acoustic values given are only valid under the measurement conditions listed and may vary depending on the installation situation. With any deviation to the standard setup, the specific values have to be checked and reviewed once installed or fitted! For detailed information see page 100 ff.

- **Motor protection:** TOP wired internally
- **Touch current:** < 0,75 mA acc. to IEC 60990 (test circuit, illustration 4)
- **Optional:** Speed monitoring via Hall IC
- **Cable exit:** Variable
- **Protection class:** I
- **Product conforming to standards:** EN 60335-1, CE
- **Approvals:** CCC is applied for

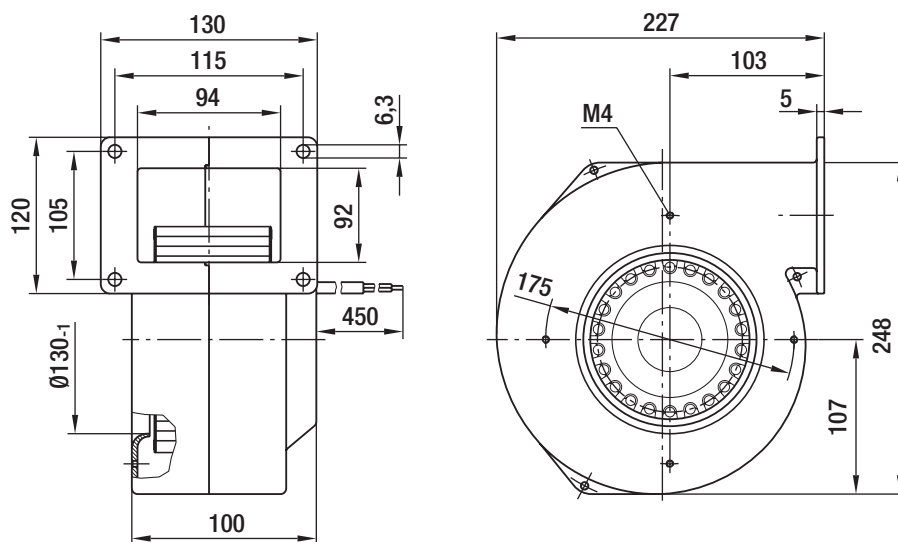

EC centrifugal blowers (ambient air)

for solid fuel heating systems, dual inlet, Ø 120



- **Material:** Housing: Galvanised sheet steel
Impeller: Galvanised sheet steel
Rotor: Uncoated
- **Direction of rotation:** Clockwise, seen on rotor
- **Type of protection:** IP 54
- **Insulation class:** "B"
- **Mounting position:** Any
- **Condensate discharges:** None (open rotor)
- **Mode of operation:** Continuous operation (S1)
- **Design:** Motor anti-vibration mounted on both sides
- **Bearings:** Maintenance-free ball bearings

Nominal data		Curve	Nominal voltage	Frequency	Air flow	Speed/rpm ⁽¹⁾	Max. input power ⁽¹⁾	Max. current draw ⁽¹⁾	Sound pressure level	Min. back pressure	Perm. amb. temp.	Mass	Electr. connection
Type	Motor	VAC	Hz	m ³ /h	rpm	W	A	dB(A)	Pa	°C	kg	p. 96	
D3G 120-AA03 -11	M3G 055-BI	Ⓐ 1~230	50/60	505	1950	83	0,74	58	0	-25..+40	2,2	H4)	

subject to alterations (1) Nominal data in operating point with maximum load and 230 VAC

Curves:

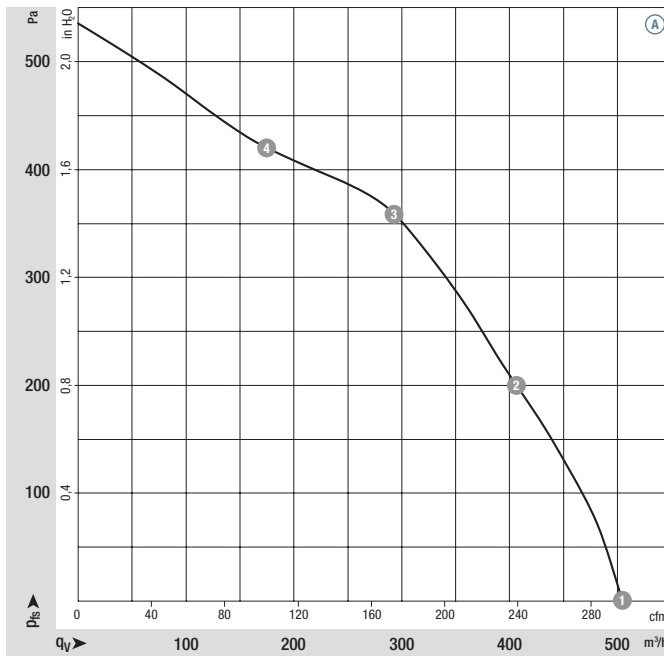

	n rpm	P _{ed} W	I A	L _{pA} dB(A)
Ⓐ 1	1950	83	0,74	58
Ⓐ 2	2465	82	0,70	57
Ⓐ 3	2970	81	0,69	59
Ⓐ 4	3245	66	0,57	60

Air performance measured as per: ISO 5801, Installation category A, with ebm-papst scroll housing without protection against accidental contact. Suction-side noise levels: L_{WA} as per ISO 13347, L_{pA} measured at 1 m distance to fan axis. The acoustic values given are only valid under the measurement conditions listed and may vary depending on the installation situation. With any deviation to the standard setup, the specific values have to be checked and reviewed once installed or fitted! For detailed information see page 100 ff.

- **Technical features:**
 - Control input 0-10 VDC / PWM
 - Output 10 VDC max. 1,1 mA
 - Over-temperature protected electronics / motor
 - **Touch current:** < 3,5 mA acc. to IEC 60990 (test circuit, illustration 4)
 - **Cable exit:** Variable
 - **Protection class:** I
 - **Product conforming to standards:** EN 60335-1, CE
- Tach output
 - Locked-rotor protection
 - Line undervoltage detection
 - Soft start

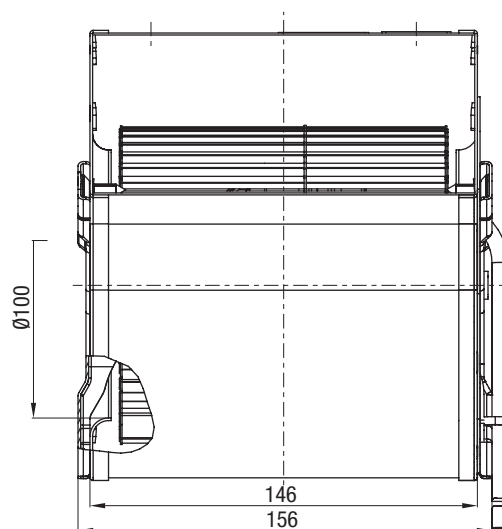
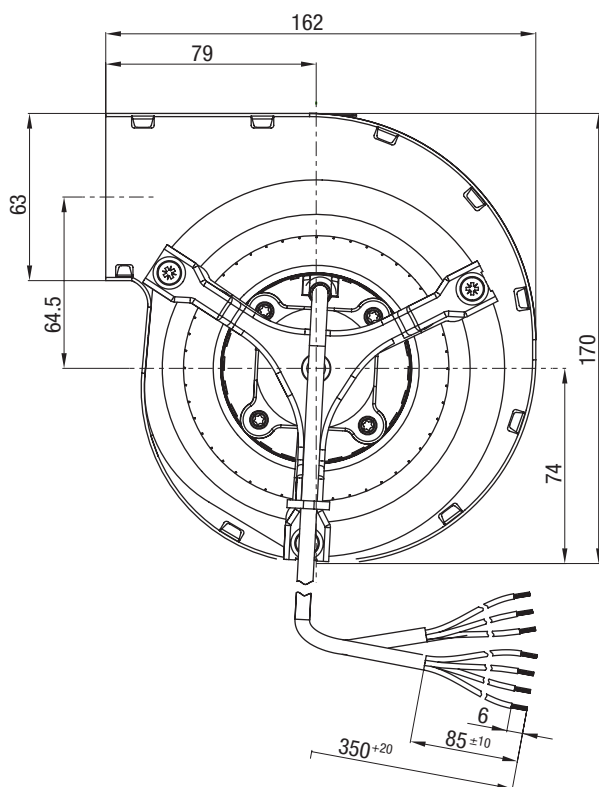

DC centrifugal blowers (ambient air)

for solid fuel heating systems, dual inlet, Ø 120



- **Material:** Housing: Galvanised sheet steel
Impeller: Galvanised sheet steel
Rotor: Coated in black
- **Direction of rotation:** Clockwise, seen on rotor
- **Type of protection:** IP 22, depending on installation and position
- **Insulation class:** "B"
- **Mounting position:** Any
- **Condensate discharges:** Rotor-side
- **Mode of operation:** Continuous operation (S1)
- **Design:** Motor anti-vibration mounted on both sides
- **Bearings:** Maintenance-free ball bearings

Nominal data		Curve	Nominal voltage	Nominal voltage range	Air flow	Speed/rpm ⁽¹⁾	Max. input power ⁽¹⁾	Max. current draw ⁽¹⁾	Sound pressure level	Min. back pressure	Perm. amb. temp.	Mass	Electr. connection
Type	Motor	VDC	VDC	m ³ /h	rpm	W	A	dB(A)	Pa	°C	kg	p. 97	
D1G 120-AA27 -01	M1G 055-CF	Ⓐ	24	16-28	500	1830	61	3,00	56	0	-25..+45	2,2	J5)

subject to alterations

Curves:

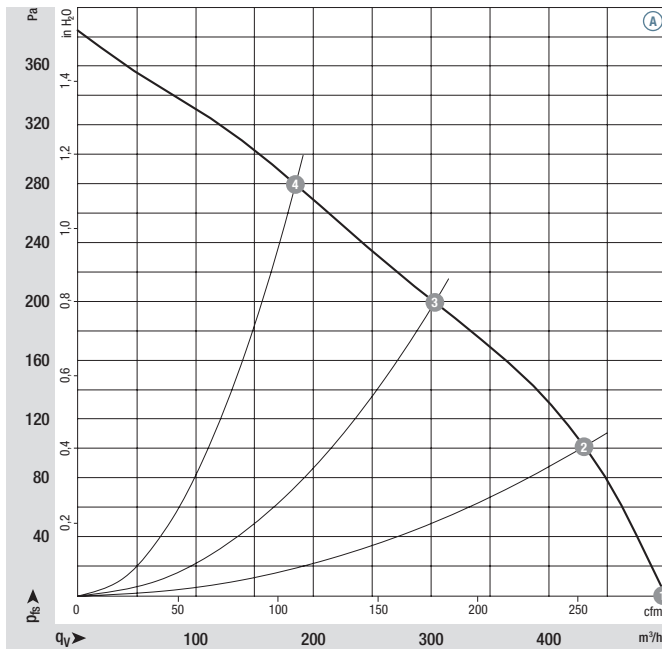

	n rpm	P _{ed} W	I A	L _{pA} dB(A)
Ⓐ 1	1830	61	3,00	56
Ⓐ 2	2020	55	2,62	55
Ⓐ 3	2360	46	2,16	54
Ⓐ 4	2595	37	1,73	55

Air performance measured as per: ISO 5801, Installation category A, with ebm-papst scroll housing without protection against accidental contact. Suction-side noise levels: L_{wa} as per ISO 13347, L_{pA} measured at 1 m distance to fan axis. The acoustic values given are only valid under the measurement conditions listed and may vary depending on the installation situation. With any deviation to the standard setup, the specific values have to be checked and reviewed once installed or fitted! For detailed information see page 100 ff.

- **Technical features:**
 - Control input 0-10 VDC / PWM
 - Motor current limitation
 - Soft start
 - Tach output
 - Reverse polarity and locked-rotor protection
 - Line undervoltage detection
- **Cable exit:** Variable
- **Protection class:** I
- **Product conforming to standards:** EN 60335-1

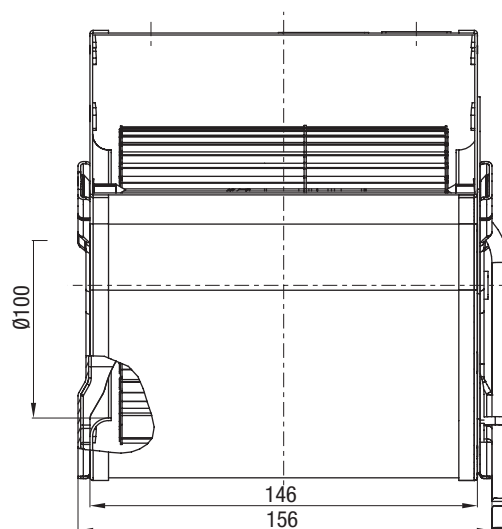
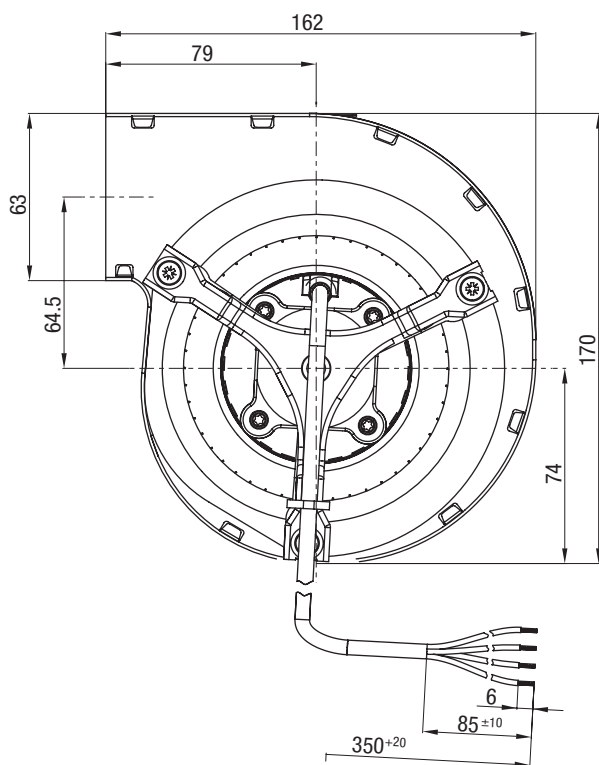

AC centrifugal blowers (ambient air)

for solid fuel heating systems, dual inlet, Ø 120

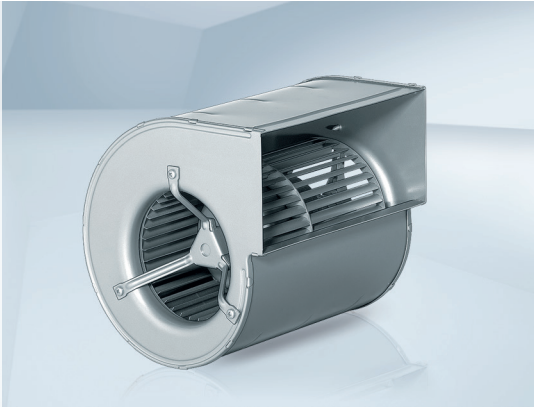

- **Material:** Housing: Galvanised sheet steel
Impeller: Galvanised sheet steel
Rotor: Uncoated
- **Direction of rotation:** Clockwise, seen on rotor
- **Type of protection:** IP 44, depending on installation and position
- **Insulation class:** "F"
- **Mounting position:** Any
- **Condensate discharges:** None
- **Mode of operation:** Continuous operation (S1)
- **Design:** Motor anti-vibration mounted on both sides
- **Bearings:** Maintenance-free ball bearings

Nominal data

Type	Motor	Curve	Nominal voltage	Frequency	Air flow	Speed/rpm	Input power	Current draw	Capacitor	Sound pressure level	Min. back pressure	Perm. amb. temp.	Mass	Electr. connection
Type	Motor	VAC	Hz	m ³ /h	rpm	W	A	µF/VDB	dB(A)	Pa	°C	kg	p. 98	
D2E 120-AA01 -04	M2E 068-BF	Ⓐ	230	50	375	1400	85	0,38	2,0/400	50	0	-25..+70	2,4	A1)

subject to alterations

Curves:

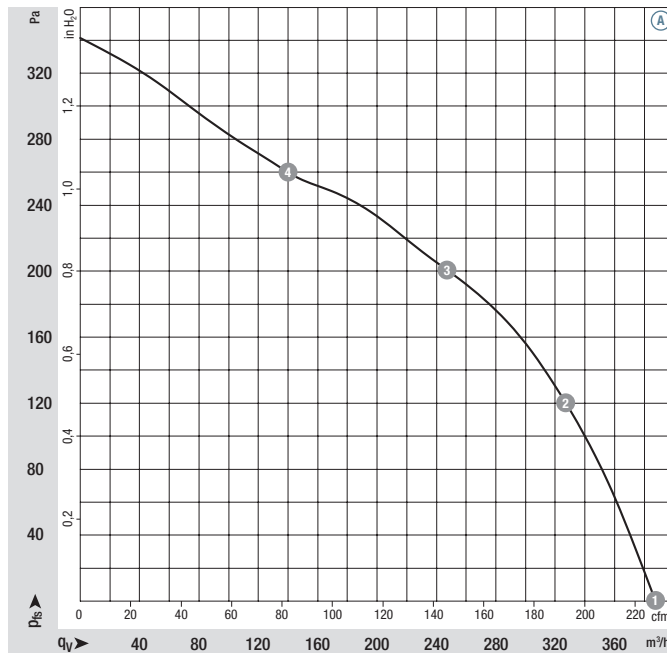

	n rpm	P _{ed} W	I A	L _{pA} dB(A)
Ⓐ 1	1400	85	0,38	50
Ⓐ 2	1905	76	0,33	51
Ⓐ 3	2265	65	0,28	52
Ⓐ 4	2500	58	0,25	53

Air performance measured as per: ISO 5801, Installation category A, with ebm-papst scroll housing without protection against accidental contact. Suction-side noise levels: L_w as per ISO 13347, L_{pA} measured at 1 m distance to fan axis. The acoustic values given are only valid under the measurement conditions listed and may vary depending on the installation situation. With any deviation to the standard setup, the specific values have to be checked and reviewed once installed or fitted! For detailed information see page 100 ff.

- **Motor protection:** TOP wired internally
- **Touch current:** < 0,75 mA acc. to IEC 60990 (test circuit, illustration 4)
- **Cable exit:** Variable
- **Protection class:** I (if customer has provided connection for protective earth)
- **Product conforming to standards:** EN 60335-1, CE

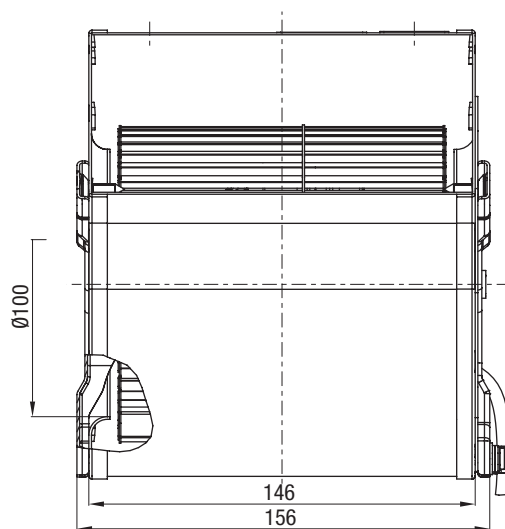
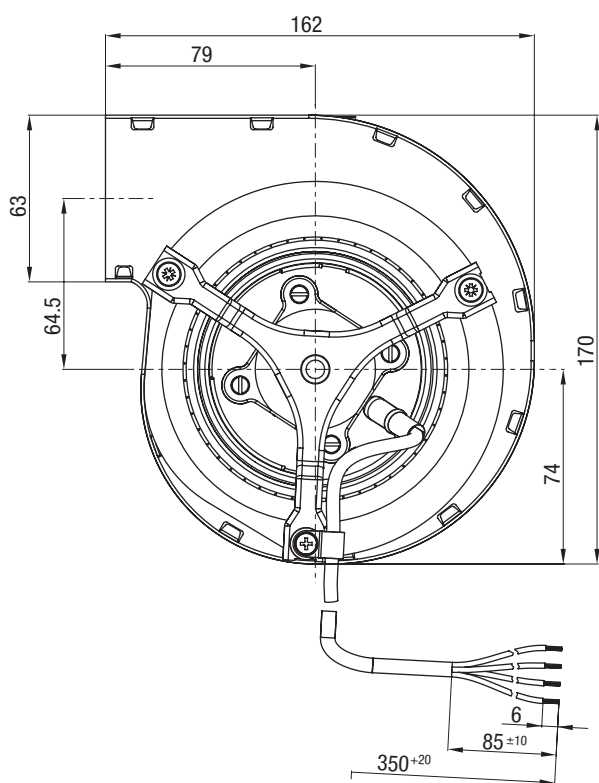

Tangential blowers (ambient air)

QLZ 06

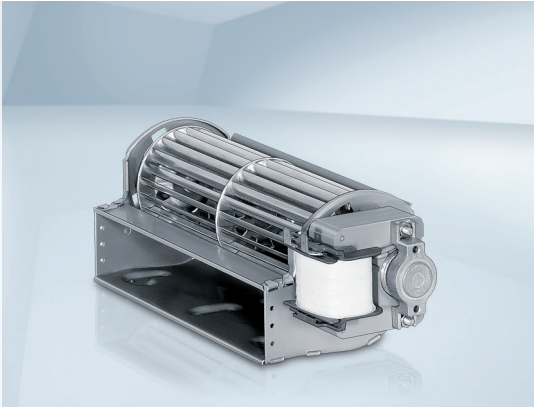

- **Impeller diameter:** 60 mm
- **Mounting position:** horizontal or vertical with motor on bottom
- **Permissible ambient temperature:** 0 - 60 °C (up to 100°C on request)
- **Insulation class:** "H"

Nominal data		Curve	Nominal voltage	Frequency	Air flow	Max. pressure increase	Input power	Current draw	Speed/rpm	Mass	Electr. connection	Dimensions (mm)					
Motor right*	Motor left	VAC	Hz	m ³ /h	Pa	W	mA	rpm	kg	p. 98	a	b	c	d	e	f	
QLZ06/2400-3030	QLZ06/0024-3030	A	230	50	170	63	34	290	1700	1,40	B)	324	62	243	253	212	93
QLZ06/3000-3038	QLZ06/0030-3038	B	230	50	230	60	45	350	1600	1,70	B)	395	72	303	313	272	123

subject to alterations

* Corresponding to dimensional drawing; Technical data are valid at free air flow and rated voltage

Curves:

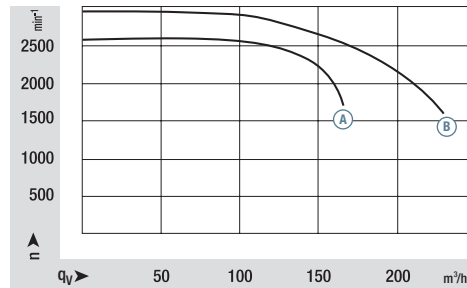
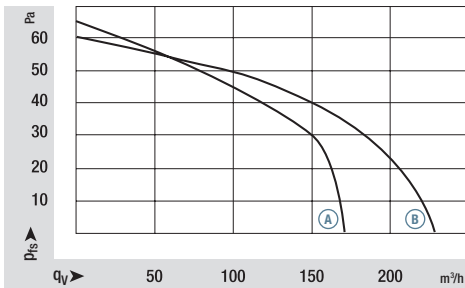

Drawings:

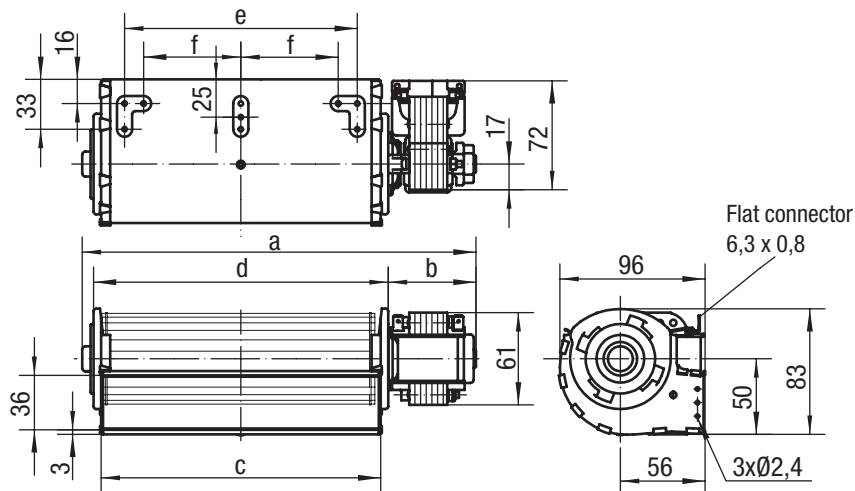

Tangential blowers (ambient air)

QLN 65

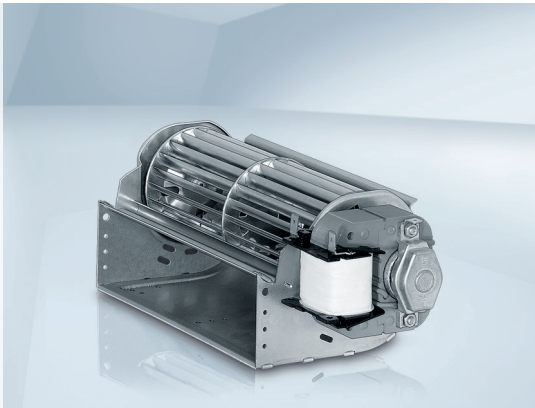

- **Impeller diameter:** 65 mm
- **Mounting position:** horizontal or vertical with motor on bottom
- **Permissible ambient temperature:** 0 - 60 °C (-40°C up to +100°C on request)
- **Insulation class:** "H"

Nominal data		Curve	Nominal voltage	Frequency	Air flow	Max. pressure increase	Input power	Current draw	Speed/rpm	Mass	Electr. connection	Dimensions (mm)					
Motor right*	Motor left	VAC	Hz	m ³ /h	Pa	W	mA	rpm	kg	p. 98	a	b	c	d	e	f	
QLN65/2400-3030	QLN65/0024-3030	A	230	50	220	80	38	360	1200	1,45	B)	331	65	242	259	212	106
QLN65/3000-3038	QLN65/0030-3038	B	230	50	250	80	45	415	1200	1,75	B)	400	73	302	319	272	136
QLN65/3600-3038	QLN65/0036-3038	C	230	50	380	95	78	700	1500	1,80	B)	460	73	362	379	332	166

subject to alterations

* Corresponding to dimensional drawing; Technical data are valid at free air flow and rated voltage

Curves:

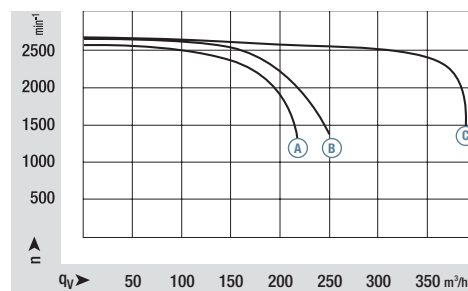
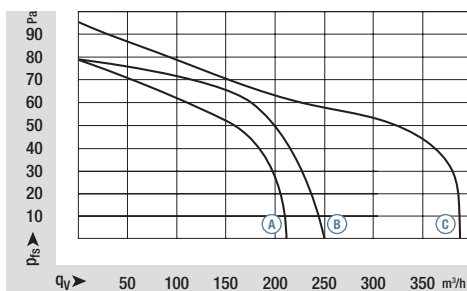

Drawings:

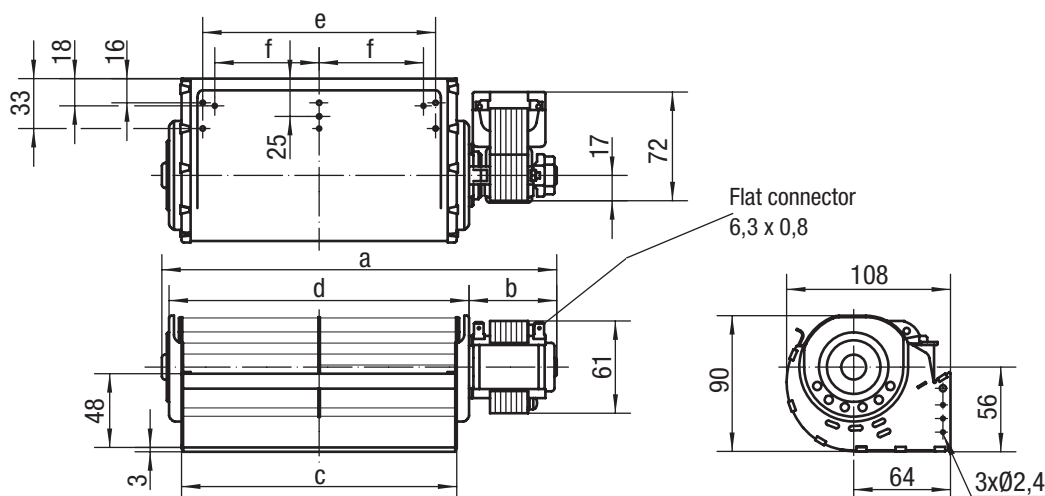

Tangential blowers (ambient air)

QLZ 06 with EC motor

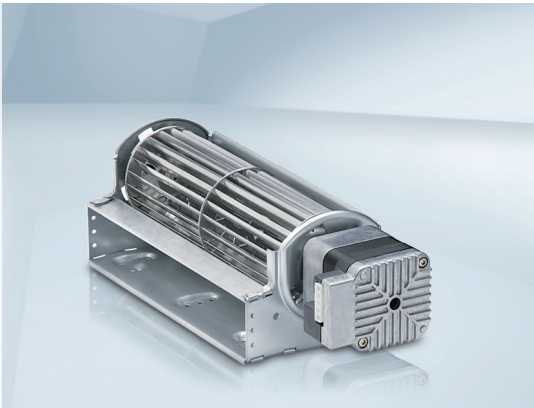

- **Electronics:** integrated
- **Blower speed:** variable via PWM signal (interface 11, standard), optionally via 0-10 V analogue voltage signal (interface 26, on request)
- **Impeller diameter:** 60 mm
- **Mounting position:** horizontal or vertical with motor on bottom
- **Permissible ambient temperature:** 0 - 60 °C
- **Insulation class:** "F"
- **Type of protection:** IP 20

Nominal data		Curve	Nominal voltage	Air flow	Max. pressure increase	Input power	Speed/rpm	Mass	Electr. connection	Dimensions (mm)					
Motor right*	Motor left	VDC	m ³ /h	Pa	W	rpm	kg	p. 94	a	b	c	d	e	f	
QLZ06/2400-2212	QLZ06/0024-2212	A	24	220	80	17	1800	0,80	11)	327	64,5	243	253	212	93
QLZ06/3000-2212	QLZ06/0030-2212	B	24	280	80	19	1850	0,85	11)	387	64,5	303	313	272	123

subject to alterations

* Corresponding to dimensional drawing; Technical data are valid at free air flow and rated voltage

Curves:

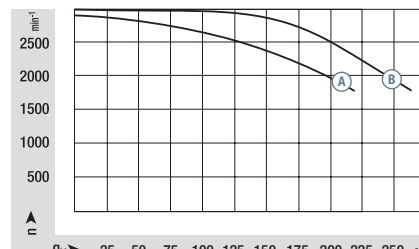
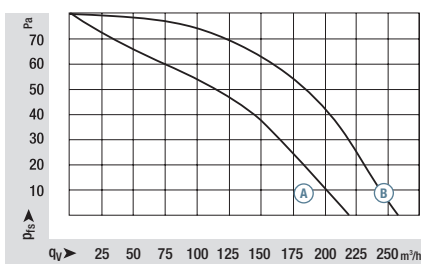

Drawings:

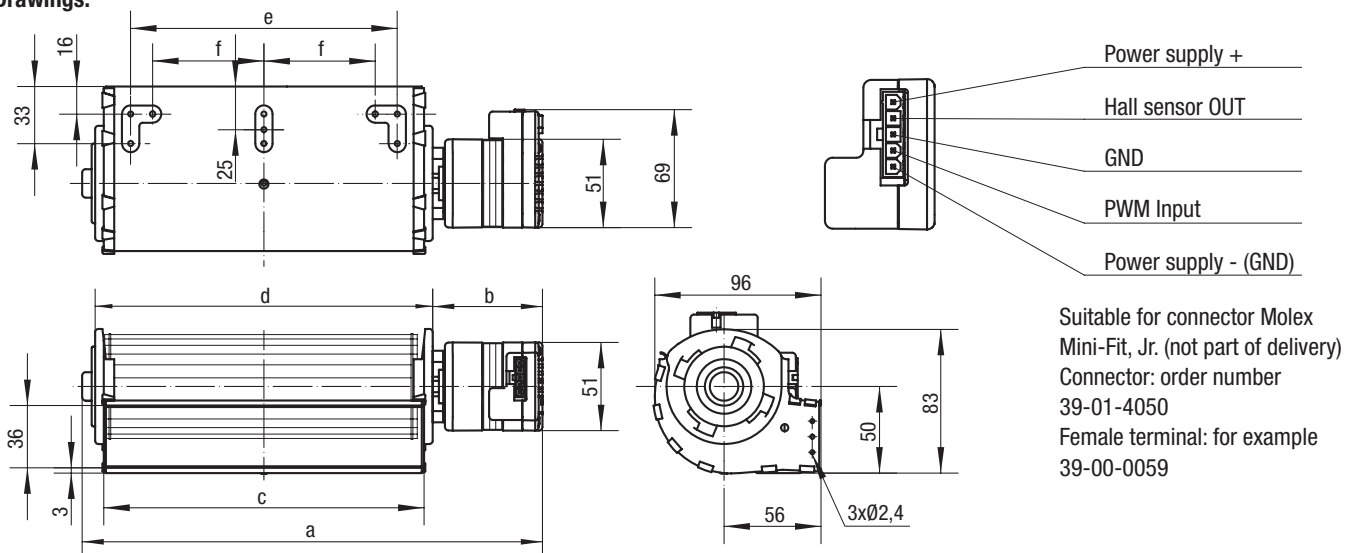

Suitable for connector Molex Mini-Fit, Jr. (not part of delivery)
 Connector: order number 39-01-4050
 Female terminal: for example 39-00-0059

Tangential blowers (ambient air)

QLN 65 with EC Motor



- **Electronics:** integrated
- **Blower speed:** variable via PWM signal (interface 11, standard), optionally via 0-10 V analogue voltage signal (interface 26, on request)
- **Impeller diameter:** 65 mm
- **Mounting position:** horizontal or vertical with motor on bottom
- **Permissible ambient temperature:** 0 - 60 °C
- **Insulation class:** "F"
- **Type of protection:** IP 20

Nominal data		Curve	Nominal voltage	Air flow	Max. pressure increase	Input power	Speed/rpm	Mass	Electr. connection	Dimensions (mm)					
Motor right*	Motor left	VDC	m ³ /h	Pa	W	rpm	kg	p. 94	a	b	c	d	e	f	
QLN65/2400-2212	QLN65/0024-2212	A	24	260	60	15	1600	0,85	11)	329	64,5	242	139	214	106
QLN65/3000-2212	QLN65/0030-2212	B	24	320	60	18	1600	0,90	11)	389	64,5	302	139	274	136
QLN65/3600-2212	QLN65/0036-2212	C	24	360	60	19	1600	0,95	11)	449	64,5	362	139	334	166

subject to alterations

* Corresponding to dimensional drawing; Technical data are valid at free air flow and rated voltage

Curves:

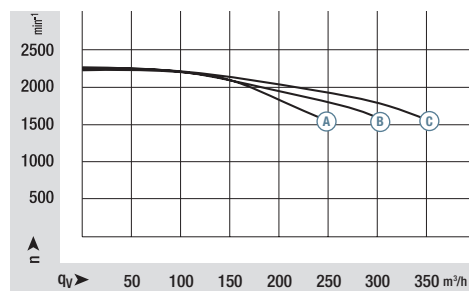
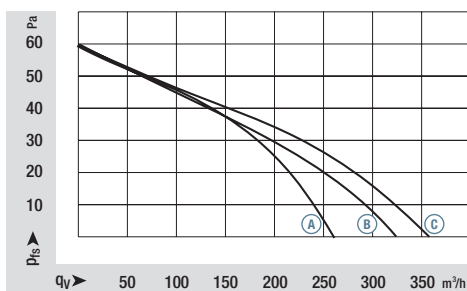

Drawings:

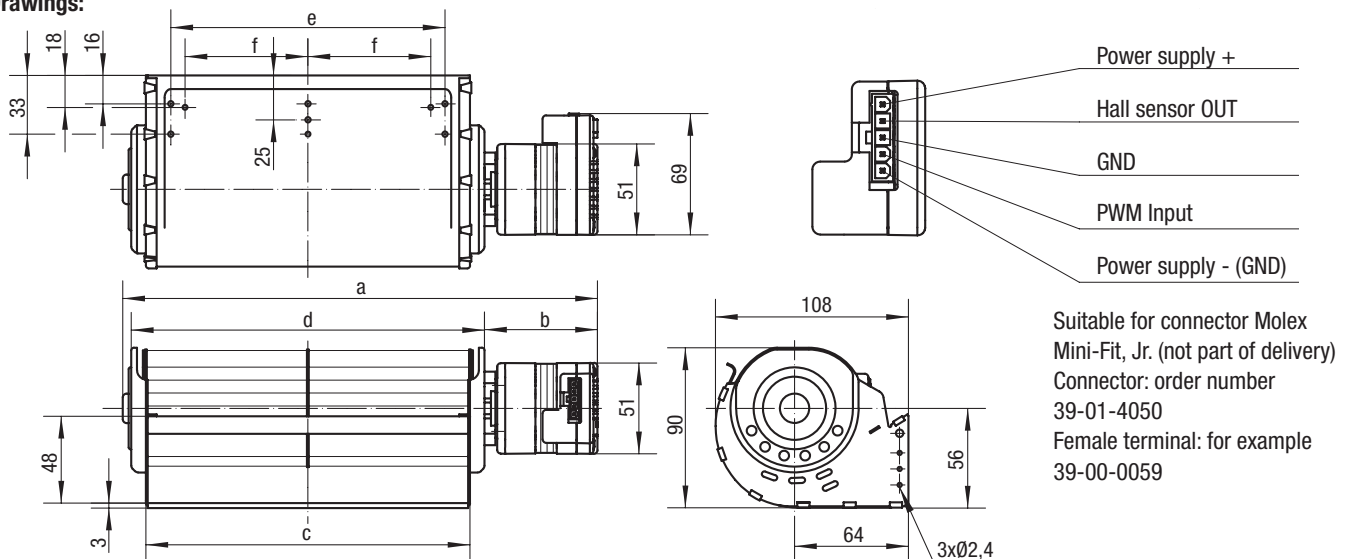



EC/AC centrifugal fans (exhaust air)



EC centrifugal fans (exhaust air)

for solid fuel heating systems, single inlet, Ø 140

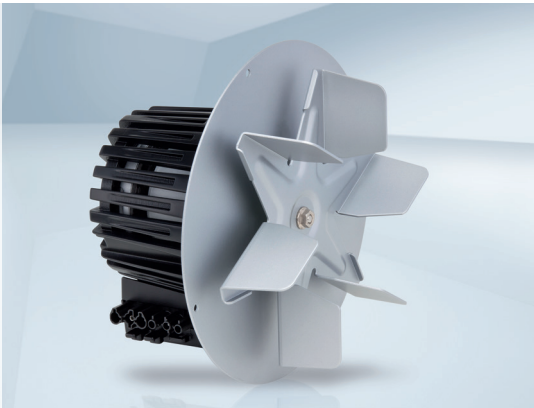

- **Material:** Impeller: Corrosion resistant sheet steel
- **Direction of rotation:** Clockwise, seen on impeller
- **Type of protection:** IP 44
- **Insulation class:** "B"
- **Mounting position:** Any
- **Condensate discharges:** None (open rotor)
- **Mode of operation:** Continuous operation (S1)
- **Bearings:** Maintenance-free ball bearings
- **Max. exhaust gas temperature:** Continuous operation 250°C

Nominal data		Curve	Nominal voltage	Frequency	Air flow	Speed/rpm	Max. input power	Max. current draw	Sound pressure level	Perm. amb. temp.	Mass	Electr. connection
Type	Motor	VAC	Hz	m ³ /h	rpm	W	A	dB(A)	°C	kg	p. 96, 99	
R3G 140-AG03 -**	M3G 055-AI	Ⓐ 1~200-240	50/60	220	2650	18	0,15	65	-25..+60	1,3	H4), C)	

subject to alterations

Curves:

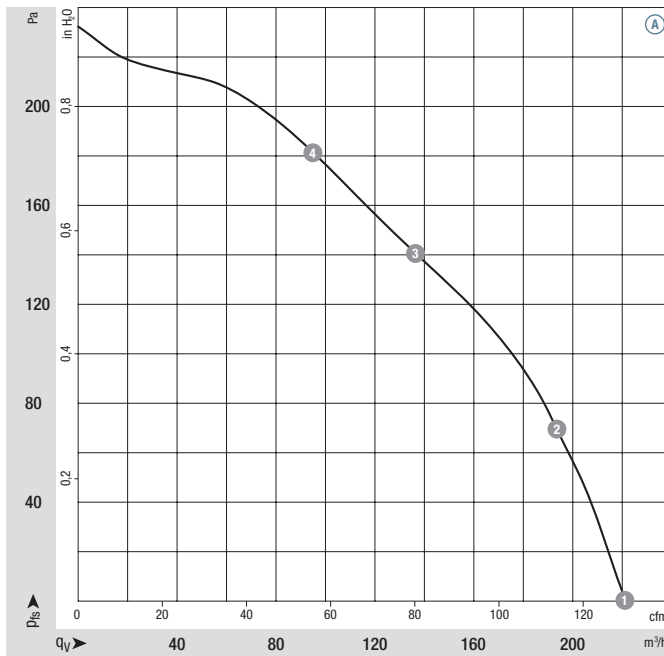

	n rpm	P _{ed} W	I A	L _{pA} dB(A)
Ⓐ 1	2650	18	0,15	---
Ⓐ 2	2635	18	0,15	---
Ⓐ 3	2660	18	0,14	---
Ⓐ 4	2690	16	0,13	---

Air performance measured as per: ISO 5801, Installation category A, with measuring device without protection against accidental contact. Suction-side noise levels: L_{WA} as per ISO 13347, L_{pA} measured at 1 m distance to fan axis. The acoustic values given are only valid under the measurement conditions listed and may vary depending on the installation situation. With any deviation to the standard setup, the specific values have to be checked and reviewed once installed or fitted! For detailed information see page 100 ff.

- **Technical features:** See electrical connections p. 96
- **EMC:** Interference emission acc. EN 61000-6-3
Interference immunity acc. EN 61000-6-2
Harmonics acc. EN 61000-3-2/3
- **Touch current:** < 3,5 mA acc. to IEC 60990 (test circuit, illustration 4)
- **Cable exit:** Variable
- **Protection class:** I (if customer has provided connection for protective earth)
- **Product conforming to standards:** EN 60335-1, CE
- **Approvals:** VDE, UL, CSA, CCC, GOST are applied for
- **Optional:** Additional shaft seal made from ceramic (see p. 94)



Selection

Dimensions

Type	Cable design	Plug design	a	b	c	d	e
R3G 140-AG03 -**	R3G 140-AG03 -01	R3G 140-AG03 -05	140	42	53,5	87	116

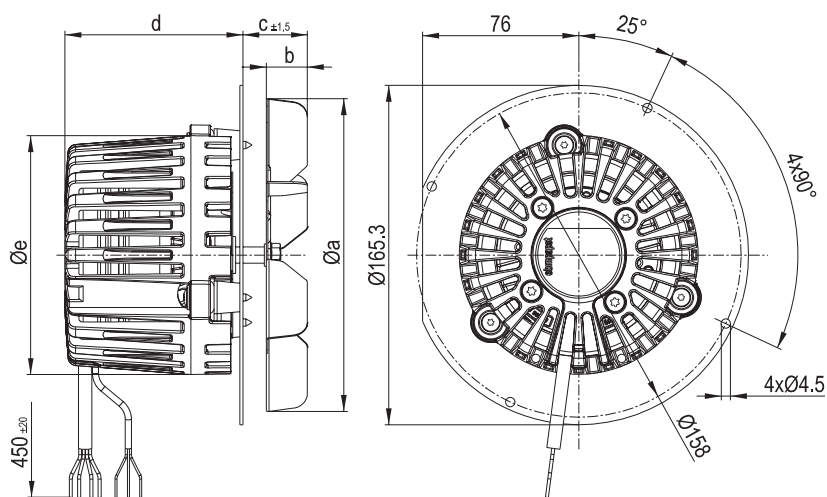

Connection:

- 1 = N (blue)
- 2 = PE (green/yellow)
- 3 = L (black)
- 4 = 0-10V/PWM (yellow)
- 5 = GND (blue)
- 6 = Tacho (white)

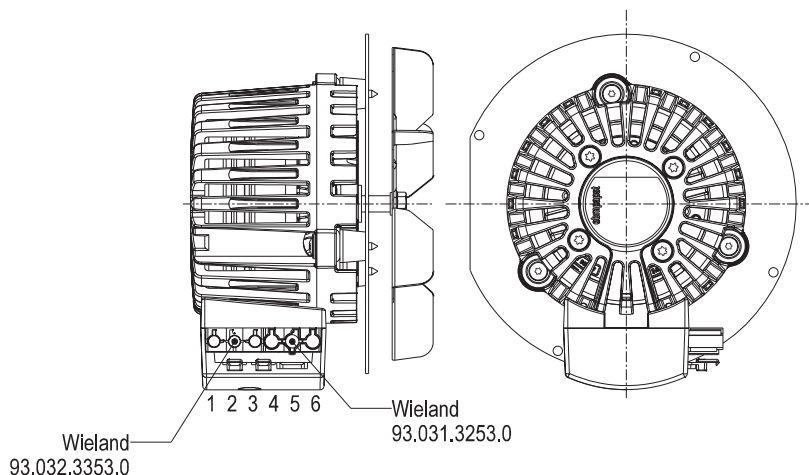

EC centrifugal fans (exhaust air)

for solid fuel heating systems, single inlet, Ø 150

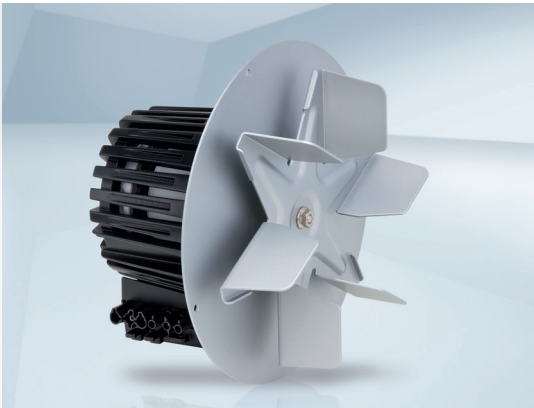

- **Material:** Impeller: Corrosion resistant sheet steel
- **Direction of rotation:** Clockwise, seen on impeller
- **Type of protection:** IP 54
- **Insulation class:** "B"
- **Mounting position:** Any
- **Condensate discharges:** None (open rotor)
- **Mode of operation:** Continuous operation (S1)
- **Bearings:** Maintenance-free ball bearings
- **Max. exhaust gas temperature:** Continuous operation 250°C

Nominal data		Curve	Nominal voltage	Frequency	Air flow	Speed/rpm	Max. input power	Max. current draw	Sound pressure level	Perm. amb. temp.	Mass	Electr. connection
Type	Motor	VAC	Hz	m ³ /h	rpm	W	A	dB(A)	°C	kg	p. 96, 99	
R3G 150-AA03 -**	M3G 055-AI	Ⓐ 1~200-240	50/60	145	2530	16	0,17	---	-25..+60	1,25	H4), C)	
R3G 150-AC01 -**	M3G 055-BD	Ⓑ 1~200-240	50/60	275	2770	30	0,30	---	-25..+60	1,45	H4), C)	

subject to alterations

Curves:

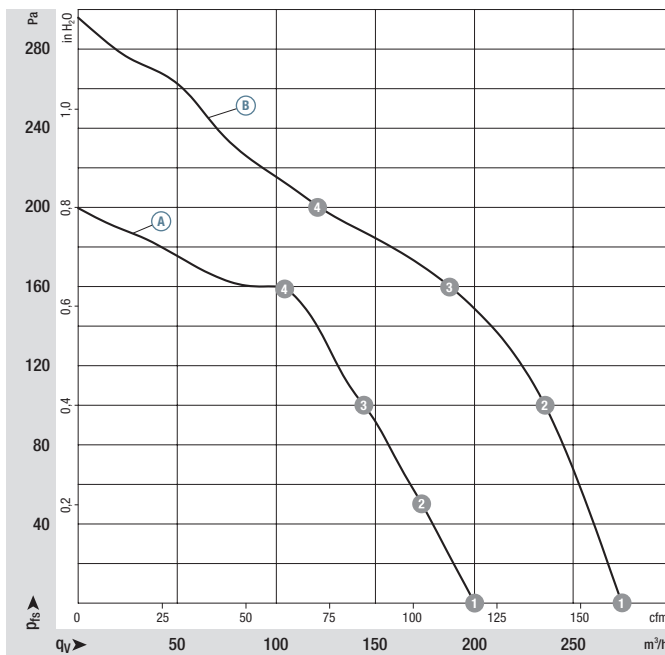

	n rpm	P _{ed} W	I A	L _{pA} dB(A)
Ⓐ ①	2530	16	0,17	---
Ⓐ ②	2540	16	0,17	---
Ⓐ ③	2600	14	0,16	---
Ⓐ ④	2650	13	0,15	---
Ⓑ ①	2803	29	0,30	---
Ⓑ ②	2770	30	0,30	---
Ⓑ ③	2796	29	0,30	---
Ⓑ ④	2830	27	0,29	---

Air performance measured as per: ISO 5801, Installation category A, without scroll housing without protection against accidental contact. Suction-side noise levels: L_{wA} as per ISO 13347, L_{pA} measured at 1 m distance to fan axis. The acoustic values given are only valid under the measurement conditions listed and may vary depending on the installation situation. With any deviation to the standard setup, the specific values have to be checked and reviewed once installed or fitted! For detailed information see page 100 ff.

- **Technical features:** See electrical connections p. 96
- **EMC:** Interference emission acc. EN 61000-6-3
Interference immunity acc. EN 61000-6-2
Harmonics acc. EN 61000-3-2/3
- **Touch current:** < 3,5 mA acc. to IEC 60990 (test circuit, illustration 4)
- **Cable exit:** Variable
- **Protection class:** I (if customer has provided connection for protective earth)
- **Product conforming to standards:** EN 60335-1, CE
- **Approvals:** VDE, UL, CSA, CCC, GOST are applied for
- **Optional:** Additional shaft seal made from ceramic (see p. 94)



Selection

Dimensions

Type	Cable design	Plug design	a	b	c	d	e
R3G 150-AA03 -**	R3G 150-AA03 -01	R3G 150-AA03 -05	152	20	31,5	87	116
R3G 150-AC01 -**	R3G 150-AC01 -01	R3G 150-AC01 -05	148	42	53,5	108	119

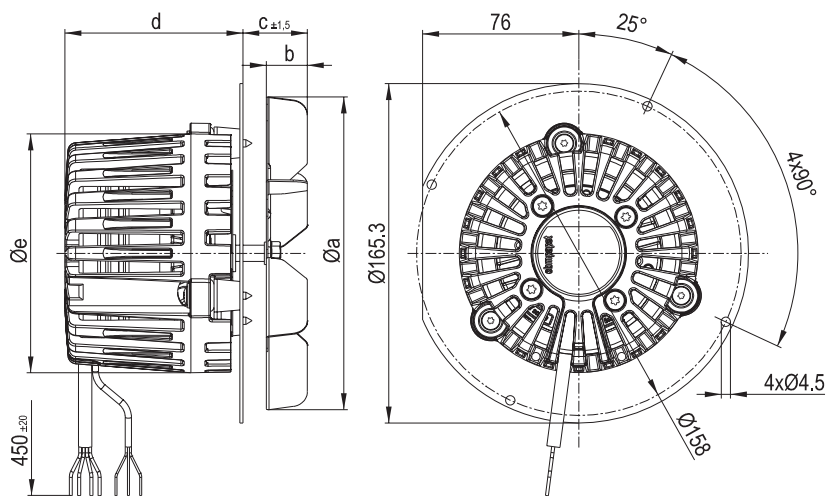

Connection:

- 1 = N (blue)
- 2 = PE (green/yellow)
- 3 = L (black)
- 4 = 0-10V/PWM (yellow)
- 5 = GND (blue)
- 6 = Tacho (white)

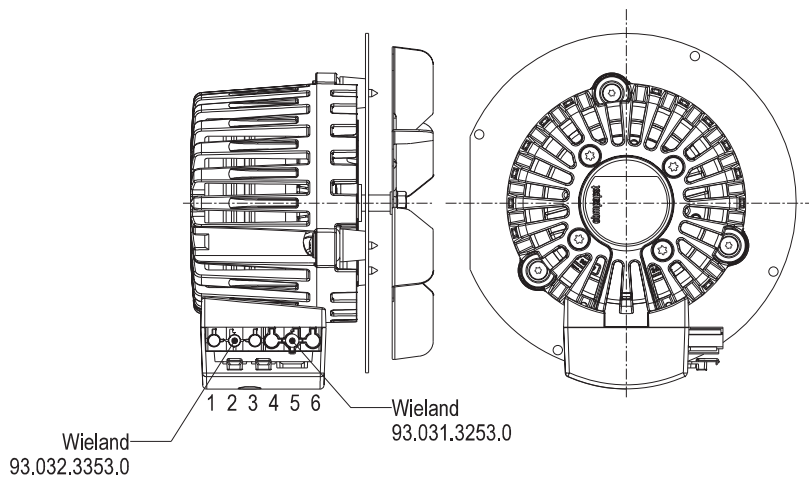

DC centrifugal fans (exhaust air)

for solid fuel heating systems, single inlet, Ø 150



- **Material:** Impeller: Corrosion resistant sheet steel
- **Direction of rotation:** Clockwise, seen on impeller
- **Type of protection:** IP 20
- **Insulation class:** "B"
- **Mounting position:** Any
- **Condensate discharges:** None (open rotor)
- **Mode of operation:** Continuous operation (S1)
- **Bearings:** Maintenance-free ball bearings
- **Max. exhaust gas temperature:** Continuous operation 250°C

Nominal data		Curve	Nominal voltage	Nominal voltage range	Air flow	Speed/rpm	Max. input power	Max. current draw	Sound pressure level	Min. back pressure	Perm. amb. temp.	Mass	Electr. connection
Type	Motor	VDC	VDC	m³/h	rpm	W	A	dB(A)	Pa	°C	kg	p. 97	
R1G 150-AA63 -**	M1G 055-BD	Ⓐ	24	16-28	290	3040	30	1,40	66	0	-25..+50	1,3	J5)
		Ⓑ	24	16-28	180	3110	28	1,31	67	0	-25..+50	1,3	

subject to alterations

Ⓐ measured without scroll housing Ⓑ measured with scroll housing

Curves:

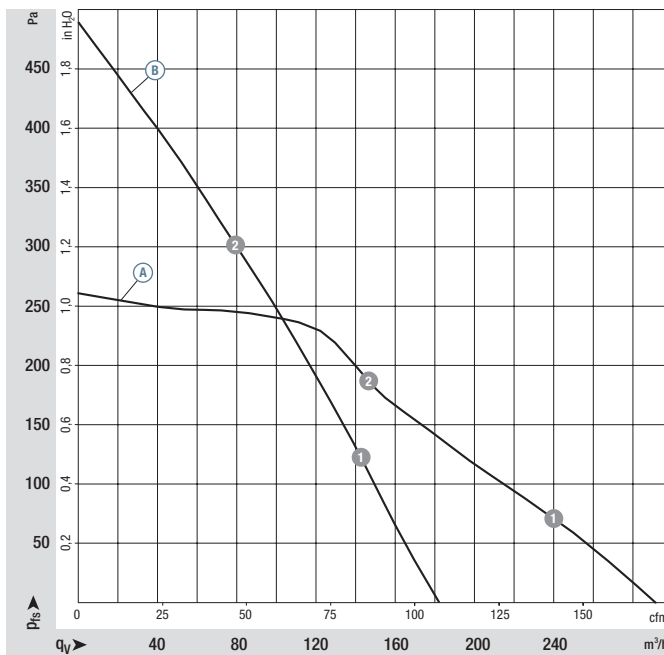

	n rpm	P _{ed} W	I A	L _{pA} dB(A)
Ⓐ 1	3030	31	1,40	---
Ⓐ 2	3110	29	1,30	---
Ⓑ 1	3190	26	1,20	---
Ⓑ 2	3360	22	1,00	---

Air performance measured as per: ISO 5801, Installation category A, without protection against accidental contact.
Suction-side noise levels: L_{WA} as per ISO 13347, L_{pA} measured at 1 m distance to fan axis. The acoustic values given are only valid under the measurement conditions listed and may vary depending on the installation situation. With any deviation to the standard setup, the specific values have to be checked and reviewed once installed or fitted! For detailed information see page 100 ff.

- **Technical features:**
 - Control input 0-10 VDC / PWM
 - Motor current limitation
 - Soft start
 - **Cable exit:** Variable
 - **Protection class:** I
 - **Product conforming to standards:** EN 60335-1
 - **Optional:** Additional shaft seal made from ceramic (see p. 94)
- Tach output
 - Reverse polarity and locked-rotor protection
 - Line undervoltage detection



Selection

Dimensions

Type	Cable design	Plug design	a	b	c	d	e
R1G 150-AA63 -**	R1G 150-AA63 -01	R1G 150-AA63 -05	148	42	53,5	108	119

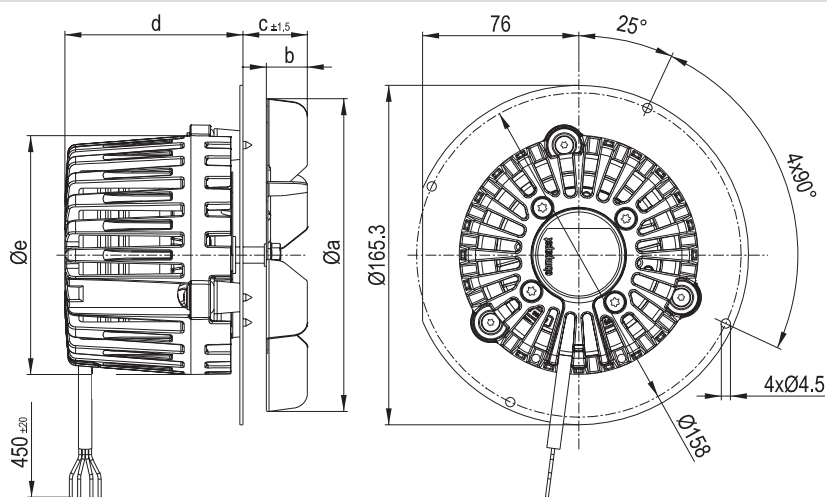

Anschluss:

- 1 = GND (blue)
- 2 = unlined
- 3 = UN +24 VDC (red)
- 4 = Tach (white)
- 5 = unlined
- 6 = 0-10 VDC (yellow)

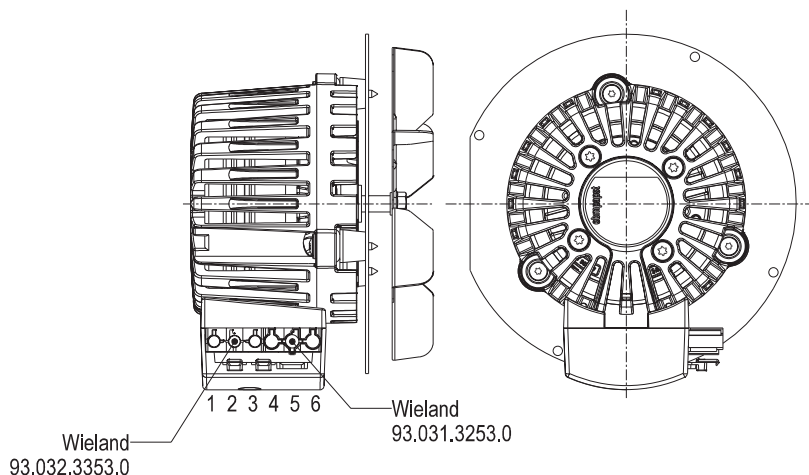

EC centrifugal fans (exhaust air)

for solid fuel heating systems, single inlet, Ø 160

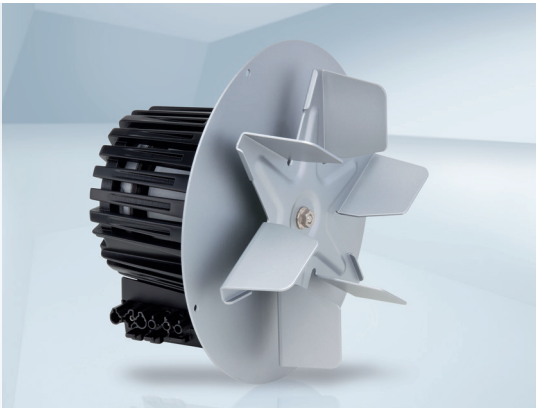

- **Material:** Impeller: Corrosion resistant sheet steel
- **Direction of rotation:** Clockwise, seen on impeller
- **Type of protection:** IP 54
- **Insulation class:** "B"
- **Mounting position:** Any
- **Condensate discharges:** None (open rotor)
- **Mode of operation:** Continuous operation (S1)
- **Bearings:** Maintenance-free ball bearings
- **Max. exhaust gas temperature:** Continuous operation 250°C

Nominal data		Curve	Nominal voltage	Frequency	Air flow	Speed/rpm	Max. input power	Max. current draw	Sound pressure level	Perm. amb. temp.	Mass	Electr. connection
Type	Motor	VAC	Hz	m ³ /h	rpm	W	A	dB(A)	°C	kg	p. 96, 99	
R3G 160-AE01 -**	M3G 055-BD	Ⓐ 1~200-240	50/60	305	2600	40	0,33	66	-25..+60	1,55	H4), C)	

subject to alterations

Curves:

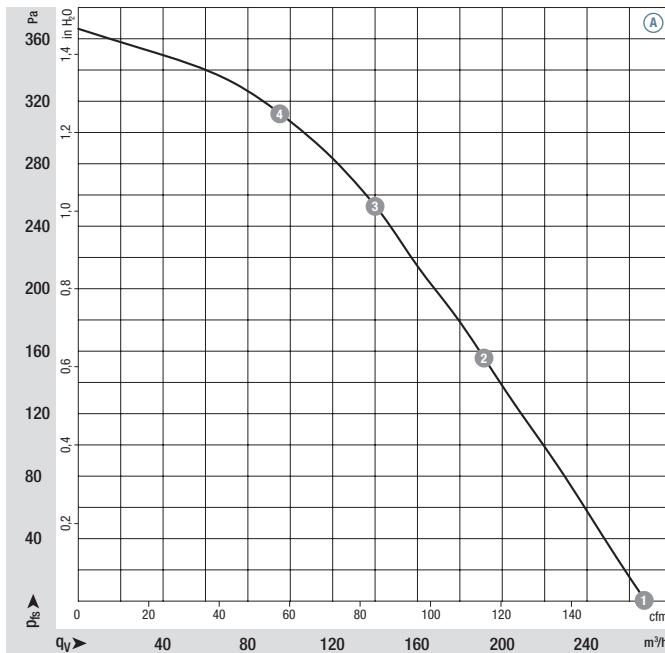

Air performance measured as per: ISO 5801, Installation category A, with scroll housing without protection against accidental contact. Suction-side noise levels: L_{wA} as per ISO 13347, L_{pA} measured at 1 m distance to fan axis. The acoustic values given are only valid under the measurement conditions listed and may vary depending on the installation situation. With any deviation to the standard setup, the specific values have to be checked and reviewed once installed or fitted! For detailed information see page 100 ff.

- **Technical features:** See electrical connections p. 96
- **EMC:** Interference emission acc. EN 61000-6-3
Interference immunity acc. EN 61000-6-2
Harmonics acc. EN 61000-3-2/3
- **Touch current:** < 3,5 mA acc. to IEC 60990 (test circuit, illustration 4)
- **Cable exit:** Variable
- **Protection class:** I (if customer has provided connection for protective earth)
- **Product conforming to standards:** EN 60335-1, CE
- **Approvals:** VDE, UL, CSA, CCC, GOST are applied for
- **Optional:** Additional shaft seal made from ceramic (see p. 94)



Selection

Dimensions

Type	Cable design	Plug design	a	b	c	d	e
R3G 160-AE01 -**	R3G 160-AE01 -01	R3G 160-AE01 -05	160	44	49,5	108	119

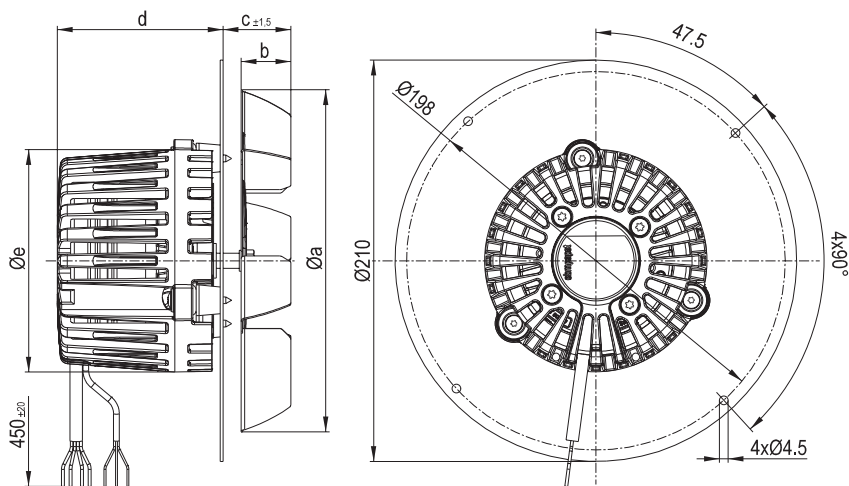

Connection:

- 1 = N (blue)
- 2 = PE (green/yellow)
- 3 = L (black)
- 4 = 0-10V/PWM (yellow)
- 5 = GND (blue)
- 6 = Tacho (white)

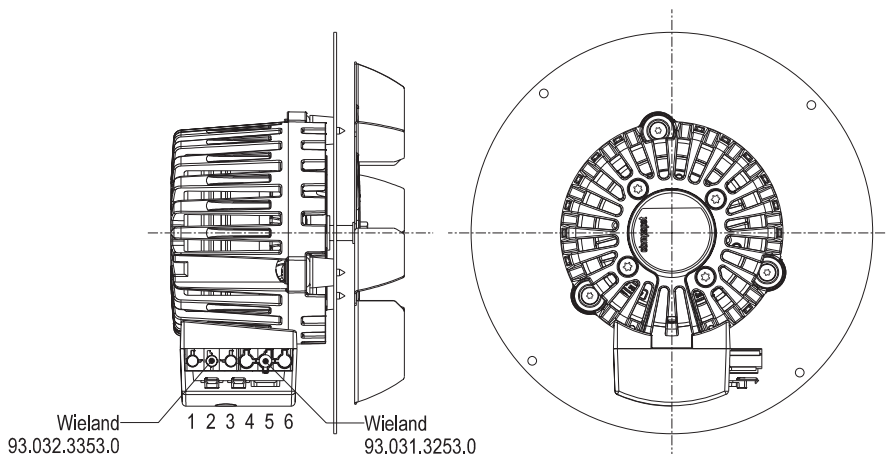

EC centrifugal fans (exhaust air)

for solid fuel heating systems, single inlet, Ø 180

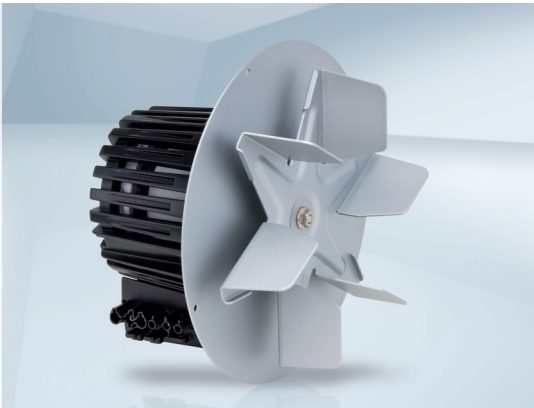

- **Material:** Impeller: Corrosion resistant sheet steel
- **Direction of rotation:** Clockwise, seen on impeller
- **Type of protection:** IP 54
- **Insulation class:** "B"
- **Mounting position:** Any
- **Condensate discharges:** None (open rotor)
- **Mode of operation:** Continuous operation (S1)
- **Bearings:** Maintenance-free ball bearings
- **Max. exhaust gas temperature:** Continuous operation 250°C

Nominal data		Curve	Nominal voltage	Frequency	Air flow	Speed/rpm	Max. input power	Max. current draw	Sound pressure level	Perm. amb. temp.	Mass	Electr. connection
Type	Motor	VAC	Hz	m ³ /h	rpm	W	A	dB(A)	°C	kg	p. 96, 99	
R3G 180-AH01 -**	M3G 055-BD	Ⓐ 1~200-240	50/60	295	2150	25	0,28	---	-25..+50	1,65	H4), C)	
R3G 180-AJ11 -**	M3G 055-CF	Ⓑ 1~200-240	50/60	440	2660	60	0,55	---	-25..+50	1,90		

subject to alterations

Curves:

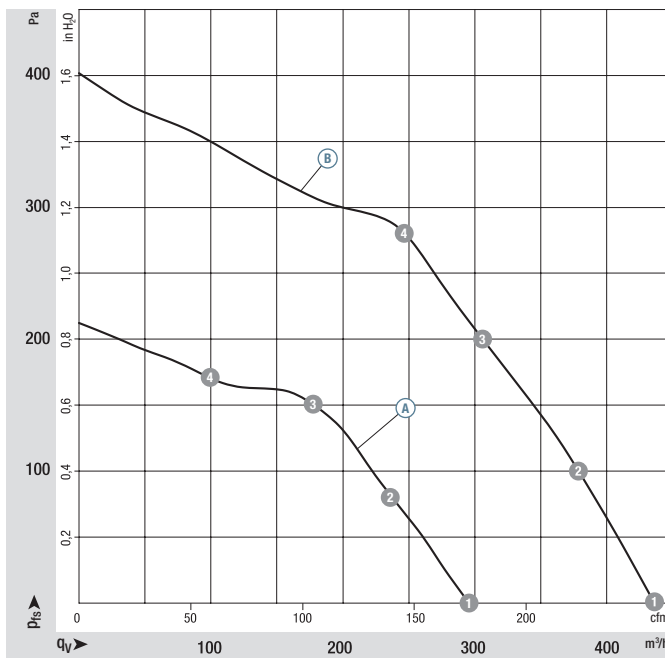

	n rpm	P _{ed} W	I A	L _{pA} dB(A)
Ⓐ 1	2150	25	0,28	---
Ⓐ 2	2150	25	0,28	---
Ⓐ 3	2220	23	0,26	---
Ⓐ 4	2285	20	0,24	---
Ⓑ 1	2660	60	0,55	---
Ⓑ 2	2635	60	0,52	---
Ⓑ 3	2685	59	0,50	---
Ⓑ 4	2730	56	0,49	---

Air performance measured as per: ISO 5801, Installation category A, with measuring device without protection against accidental contact. Suction-side noise levels: L_{WA} as per ISO 13347, L_{pA} measured at 1 m distance to fan axis. The acoustic values given are only valid under the measurement conditions listed and may vary depending on the installation situation. With any deviation to the standard setup, the specific values have to be checked and reviewed once installed or fitted! For detailed information see page 100 ff.

- **Technical features:** See electrical connections p. 96
- **EMC:** Interference emission acc. EN 61000-6-3
Interference immunity acc. EN 61000-6-2
Harmonics acc. EN 61000-3-2/3
- **Touch current:** < 3,5 mA acc. to IEC 60990 (test circuit, illustration 4)
- **Cable exit:** Variable
- **Protection class:** I (if customer has provided connection for protective earth)
- **Product conforming to standards:** EN 60335-1, CE
- **Approvals:** VDE, UL, CSA, CCC, GOST are applied for
- **Optional:** Additional shaft seal made from ceramic (see p. 94)



Selection

Dimensions

Type	Cable design	Plug design	a	b	c	d	e
R3G 180-AH01 -**	R3G 180-AH01 -01	R3G 180-AH01 -05	180	26	44,5	108	119
R3G 180-AJ11 -**	R3G 180-AJ11 -01	R3G 180-AJ11 -05	180	45	54,5	108	119

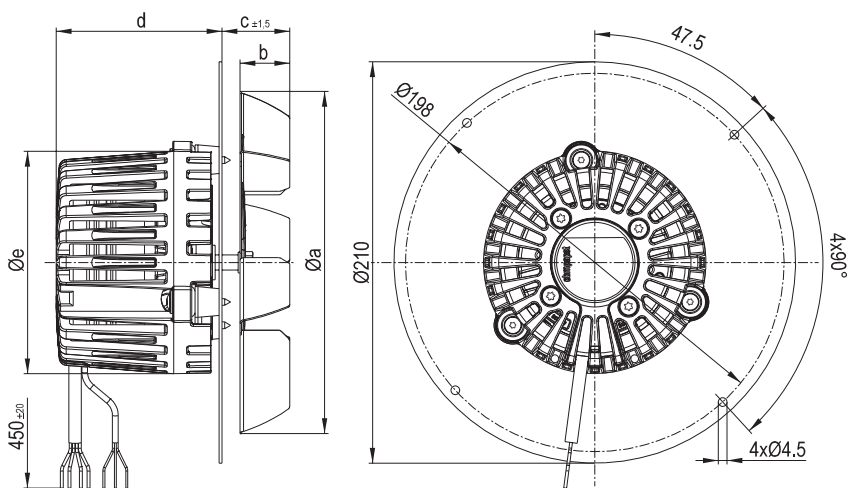

Connection:

- 1 = N (blue)
- 2 = PE (green/yellow)
- 3 = L (black)
- 4 = 0-10V/PWM (yellow)
- 5 = GND (blue)
- 6 = Tacho (white)

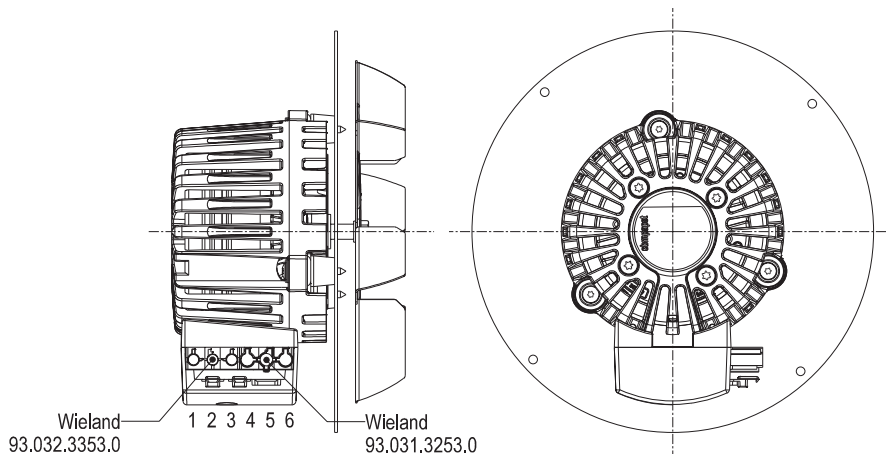

EC centrifugal fans (exhaust air)

for solid fuel heating systems, single inlet, Ø 210

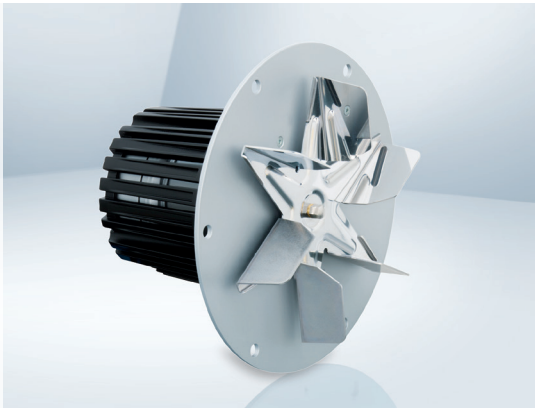

- **Material:** Impeller: Corrosion resistant sheet steel
- **Direction of rotation:** Clockwise, seen on impeller
- **Type of protection:** IP 54
- **Insulation class:** "B"
- **Mounting position:** Any
- **Condensate discharges:** None (open rotor)
- **Mode of operation:** Continuous operation (S1)
- **Bearings:** Maintenance-free ball bearings
- **Max. exhaust gas temperature:** Continuous operation 250°C

Nominal data		Curve	Nominal voltage	Frequency	Air flow	Speed/rpm	Max. input power	Max. current draw	Sound pressure level	Perm. amb. temp.	Mass	Electr. connection
Type	Motor	VAC	Hz	m ³ /h	rpm	W	A	dB(A)	°C	kg	p. 95, 99	
R3G 210-AA73 -**	M3G 074-CF	Ⓐ 1~200-240	50/60	495	3200	170	1,35	---	-25..+40	4,5	H1), C)	

subject to alterations

Curves:

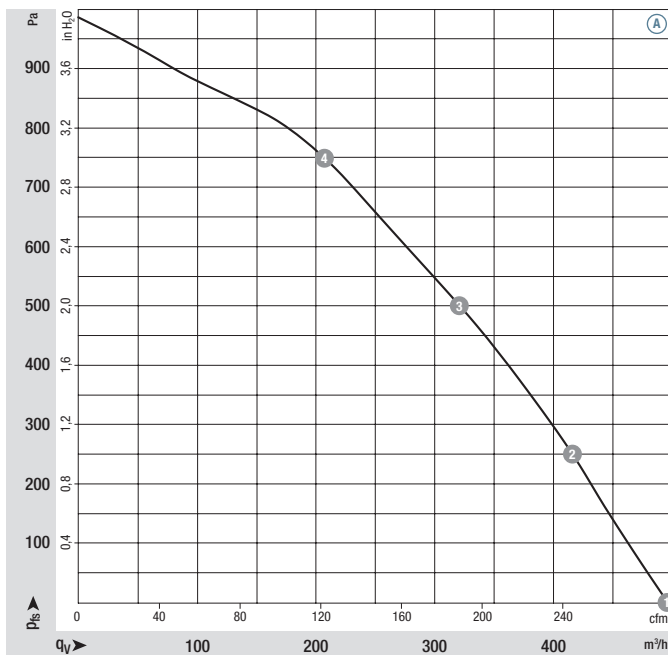

	n rpm	P _{ed} W	I A	L _{pA} dB(A)
Ⓐ 1	3200	170	1,35	---
Ⓐ 2	3230	159	1,29	---
Ⓐ 3	3260	141	1,16	---
Ⓐ 4	3310	118	0,99	---

Air performance measured as per: ISO 5801, Installation category A, with scroll housing without protection against accidental contact. Suction-side noise levels: L_{wA} as per ISO 13347, L_{pA} measured at 1 m distance to fan axis. The acoustic values given are only valid under the measurement conditions listed and may vary depending on the installation situation. With any deviation to the standard setup, the specific values have to be checked and reviewed once installed or fitted! For detailed information see page 100 ff.

- **Technical features:**
 - PFC (passive)
 - Control input 0-10 VDC / PWM
 - Output 10 VDC max. 1,1 mA
 - Tach output
 - Over-temperature protected electronics / motor
- **EMC:** Interference emission acc. EN 61000-6-3
Interference immunity acc. EN 61000-6-2
Harmonics acc. EN 61000-3-2/3
- **Touch current:** < 3,5 mA acc. to IEC 60990 (test circuit, illustration 4)
- **Cable exit:** Variable
- **Protection class:** I (if customer has provided connection for protective earth)
- **Product conforming to standards:** EN 60335-1, EN 61800-5-1, EN 60950-1, CE
- **Approvals:** UL, CSA, CCC, GOST are applied for
- **Optional:** Additional shaft seal made from ceramic (see p. 94)



Selection

Type	Cable design	Plug design
R3G 210-AA73 -**	R3G 210-AA73 -01	R3G 210-AA73 -05

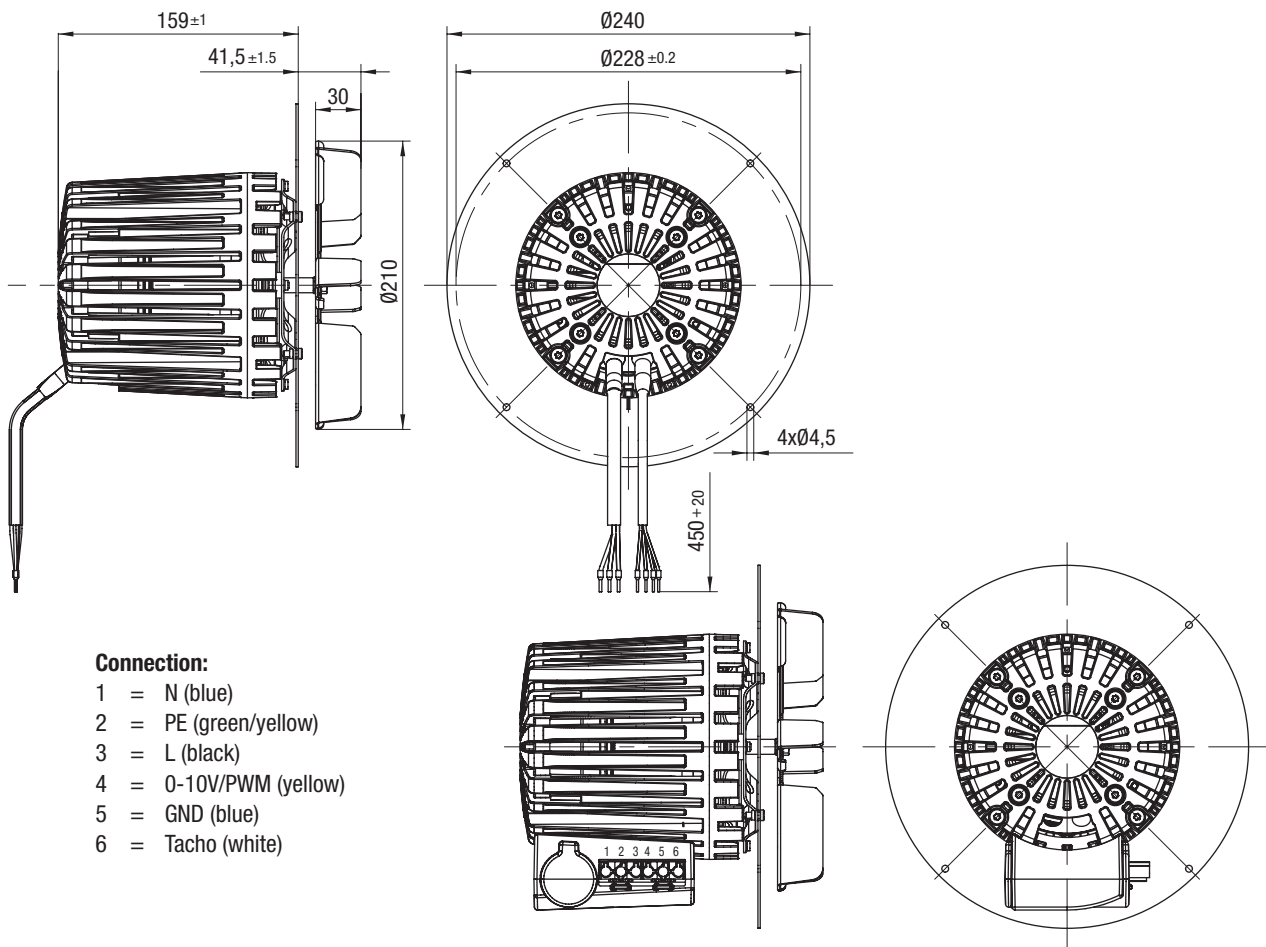

AC centrifugal fans (exhaust air)

for solid fuel heating systems, single inlet, Ø 152

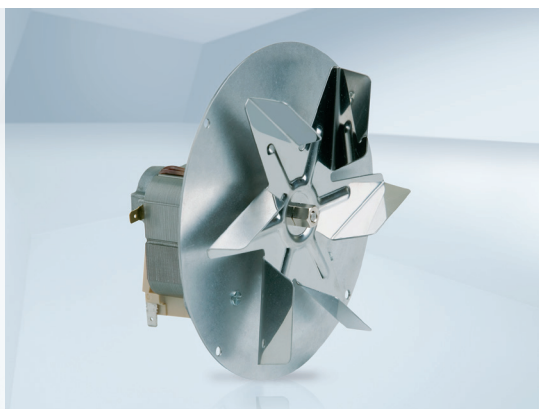

- **Material:** Impeller: Corrosion resistant stainless steel
- **Direction of rotation:** Clockwise, seen on impeller
- **Type of protection:** IP 00
- **Insulation class:** "H"
- **Mounting position:** Shaft position horizontal or shaft position vertical (motor on top)
- **Mode of operation:** Continuous operation (S1)
- **Bearings:** Sleeve bearings / ball bearings

Nominal data		Curve	Nominal voltage	Frequency	Air flow	Speed/rpm	Max. input power	Max. current draw	Sound pressure level	Perm. amb. temp.	Mass	Electr. connection
Type	Motor	VAC	Hz	m ³ /h	rpm	W	A	dB(A)	°C	kg	p. 98	
RR 152 - 3030 LH	EM 3030	Ⓐ	230	50	235	2575	44	0,37	61	-25..+85	1,00	B)
		Ⓑ	230	50	150	2600	44	0,37	62	-25..+85	1,00	

subject to alterations

Ⓐ measured without ebm-papst scroll housing Ⓑ measured with ebm-papst scroll housing

Curves:

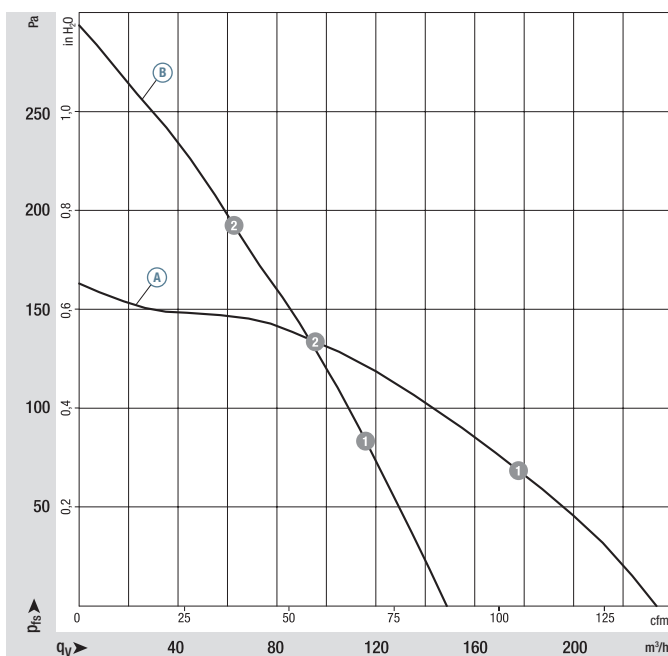

	n rpm	P _{ed} W	I A	L _{pA} dB(A)
Ⓐ 1	2540	45	---	---
Ⓐ 2	2620	42	---	---
Ⓑ 1	2640	42	---	---
Ⓑ 2	2730	39	---	---

Air performance measured as per: ISO 5801, Installation category A, without protection against accidental contact.
Suction-side noise levels: L_{WA} as per ISO 13347, L_{pA} measured at 1 m distance to fan axis. The acoustic values given are only valid under the measurement conditions listed and may vary depending on the installation situation. With any deviation to the standard setup, the specific values have to be checked and reviewed once installed or fitted! For detailed information see page 100 ff.

- **Electrical connection:** via flat pin
- **Optional:** Hall IC connection, motor protection hood
- **Protection class:** I
- **Product conforming to standards:** EN 60335-1
- **Approvals:** VDE-compliant design, optionally UL-compliant design possible

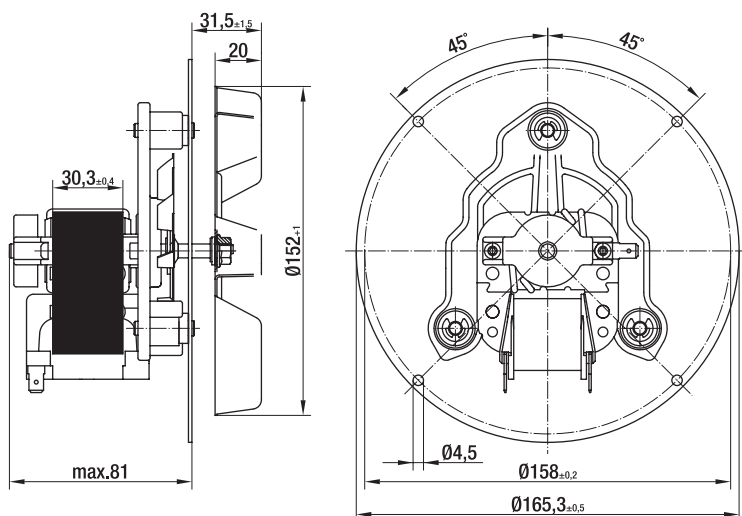

AC centrifugal fans (exhaust air)

for solid fuel heating systems, single inlet, Ø 140

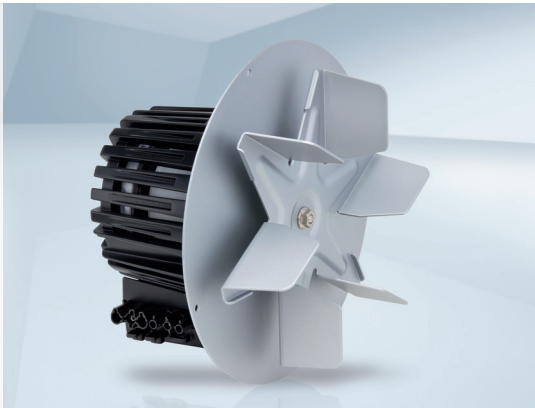

- **Material:** Impeller: Corrosion resistant sheet steel
- **Direction of rotation:** Clockwise, seen on impeller
- **Type of protection:** IP 44, depending on installation and position
- **Insulation class:** "F"
- **Mounting position:** Any
- **Condensate discharges:** None
- **Mode of operation:** Continuous operation (S1)
- **Bearings:** Maintenance-free ball bearings
- **Max. exhaust gas temperature:** Continuous operation 250°C

Nominal data		Curve	Nominal voltage	Frequency	Air flow	Speed/rpm	Max. input power	Max. current draw	Capacitor	Sound pressure level	Perm. amb. temp.	Mass	Electr. connection
Type	Motor	VAC	Hz	m ³ /h	rpm	W	A	µF/VDB	dB(A)	°C	kg	p. 98, 99	
R2E 140-CD76 -**	M2E 068-BF	Ⓐ 230	50	215	2650	28	0,14	0,68/400	---	-25..+60	1,6	A1), D)	

subject to alterations

Curves:

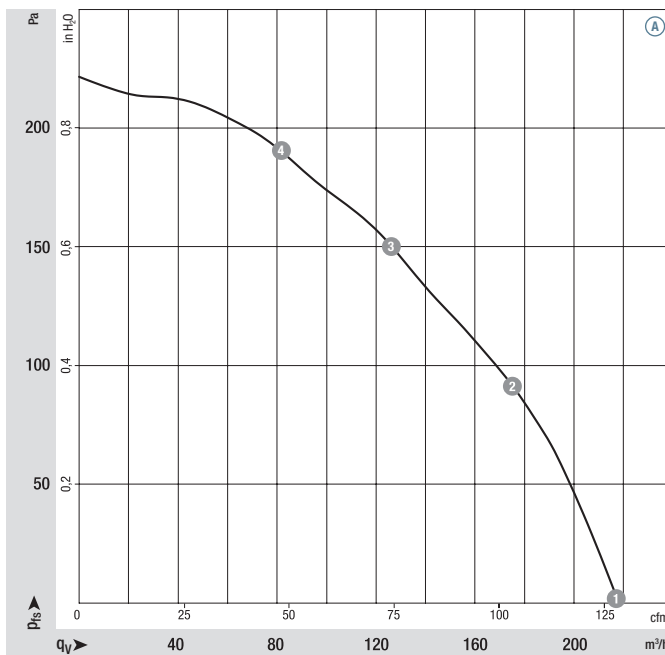

	n rpm	P _{ed} W	I A	L _{pA} dB(A)
Ⓐ 1	2650	28	0,14	---
Ⓐ 2	2635	28	0,14	---
Ⓐ 3	2660	28	0,13	---
Ⓐ 4	2695	26	0,12	---

Air performance measured as per: ISO 5801, Installation category A, without scroll housing without protection against accidental contact. Suction-side noise levels: L_{wA} as per ISO 13347, L_{pA} measured at 1 m distance to fan axis. The acoustic values given are only valid under the measurement conditions listed and may vary depending on the installation situation. With any deviation to the standard setup, the specific values have to be checked and reviewed once installed or fitted! For detailed information see page 100 ff.

- **Motor protection:** TOP wired internally
- **Touch current:** < 0,75 mA acc. to IEC 60990 (test circuit, illustration 4)
- **Standard:** Speed monitoring via Hall IC
- **Optional:** also possible, without protection hood
- **Cable exit:** Variable
- **Protection class:** I (if customer has provided connection for protective earth)
- **Product conforming to standards:** EN 60335-1, CE
- **Approvals:** UL, CSA, CCC, GOST are applied for
- **Optional:** Additional shaft seal made from ceramic (see p. 94)



Selection

Dimensions

Type	Cable design	Plug design	a	b	c	d	e
R2E 140-CD76 -**	R2E 140-CD76 -01	R2E 140-CD76 -05	140	42	53,5	87	116

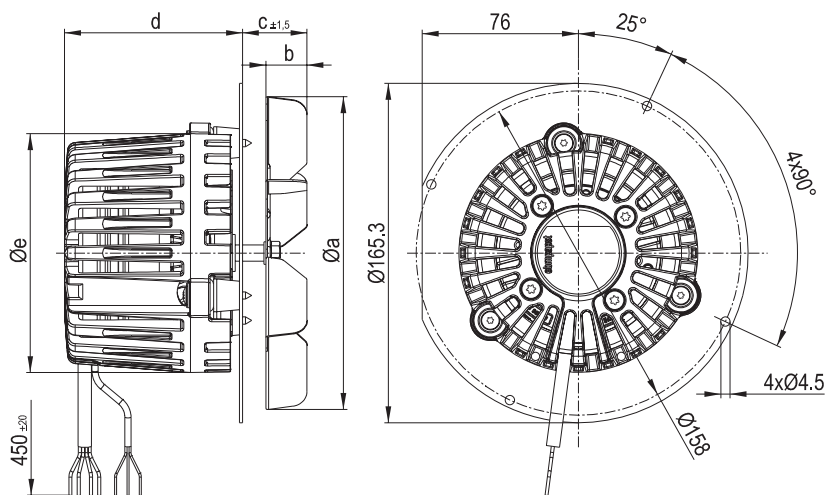

Connection:

- 1 = L (blue)
- 2 = PE (green/yellow)
- 3 = N (black)
- 4 = GND (black)
- 5 = OUT (white)
- 6 = VCC (red)

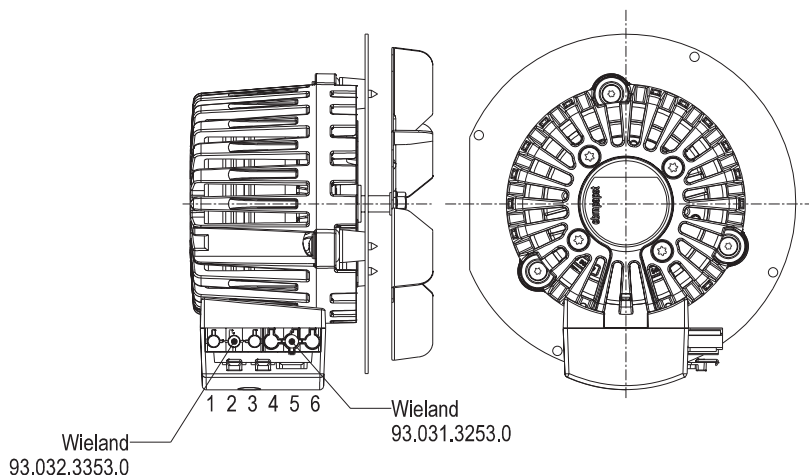

AC centrifugal fans (exhaust air)

for solid fuel heating systems, single inlet, Ø 150

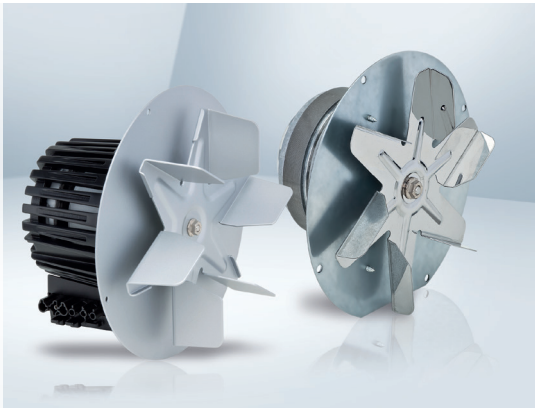

- **Material:** Impeller: Corrosion resistant sheet steel
- **Direction of rotation:** Clockwise, seen on impeller
- **Type of protection:** IP 44, depending on installation and position
- **Insulation class:** "F"
- **Mounting position:** Any
- **Condensate discharges:** None
- **Mode of operation:** Continuous operation (S1)
- **Bearings:** Maintenance-free ball bearings
- **Max. exhaust gas temperature:** Continuous operation 250°C

Nominal data		Curve	Nominal voltage	Frequency	Air flow	Speed/rpm	Max. input power	Max. current draw	Capacitor	Sound pressure level	Perm. amb. temp.	Mass	Electr. connection
Type	Motor	VAC	Hz	m ³ /h	rpm	W	A	µF/VDB	dB(A)	°C	kg	p. 98, 99	
R2E 150-A091 -**	M2E 068-BF	Ⓐ	230	50	200	2400	32	0,15	1,0/400	---	-25..+55	1,7	A1), D)
R2E 150-AN91 -**		Ⓐ	230	50	200	2400	32	0,15	1,0/400	---	-25..+75	1,7	

subject to alterations

Curves:

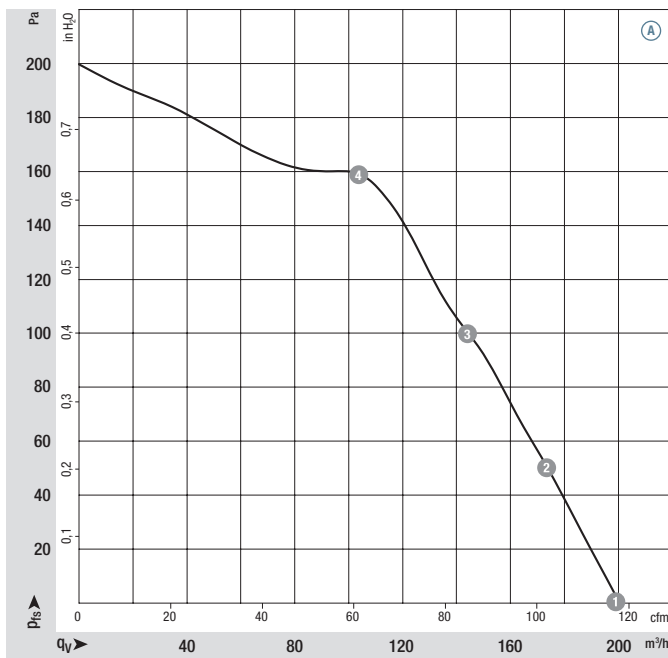

	n rpm	P _{ed} W	I A	L _{pA} dB(A)
Ⓐ 1	2400	32	0,15	---
Ⓐ 2	2410	31	0,14	---
Ⓐ 3	2435	31	0,14	---
Ⓐ 4	2485	30	0,13	---

Air performance measured as per: ISO 5801, Installation category A, without scroll housing without protection against accidental contact. Suction-side noise levels: L_{wA} as per ISO 13347, L_{pA} measured at 1 m distance to fan axis. The acoustic values given are only valid under the measurement conditions listed and may vary depending on the installation situation. With any deviation to the standard setup, the specific values have to be checked and reviewed once installed or fitted! For detailed information see page 100 ff.

- **Motor protection:** TOP wired internally
- **Touch current:** < 0,75 mA acc. to IEC 60990 (test circuit, illustration 4)
- **Standard:** Speed monitoring via Hall IC
- **Cable exit:** Variable
- **Protection class:** I (if customer has provided connection for protective earth)
- **Product conforming to standards:** EN 60335-1, CE
- **Approvals:** UL, CSA, CCC, GOST are applied for
- **Optional:** Additional shaft seal made from ceramic (see p. 94)

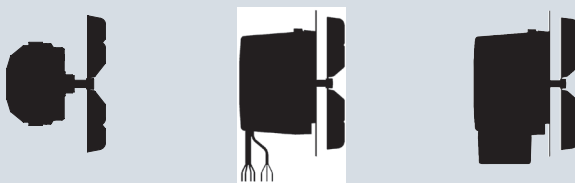

Selection

Dimensions

Type	without motor protection hood	Cable design	Plug design	a	b	c	d	e
R2E 150-A091 -**	---	R2E 150-A091 -01	R2E 150-A091 -05	152	20	31,5	87	116
R2E 150-AN91 -**	R2E 150-AN91 -01	---	---	---	---	---	---	---

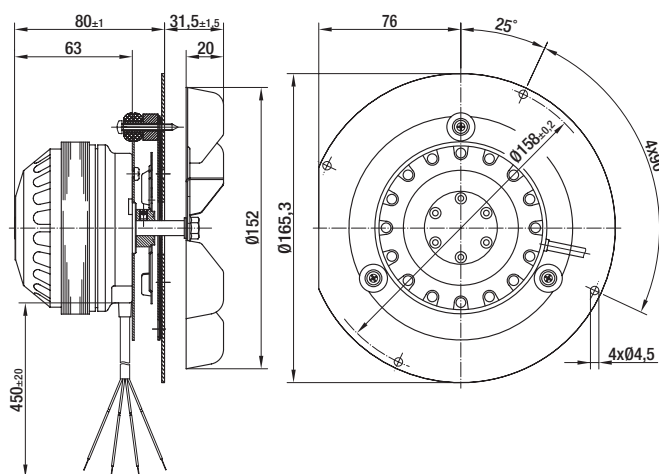

Connection:

- 1 = L (blue)
- 2 = PE (green/yellow)
- 3 = N (black)
- 4 = GND (black)
- 5 = OUT (white)
- 6 = VCC (red)

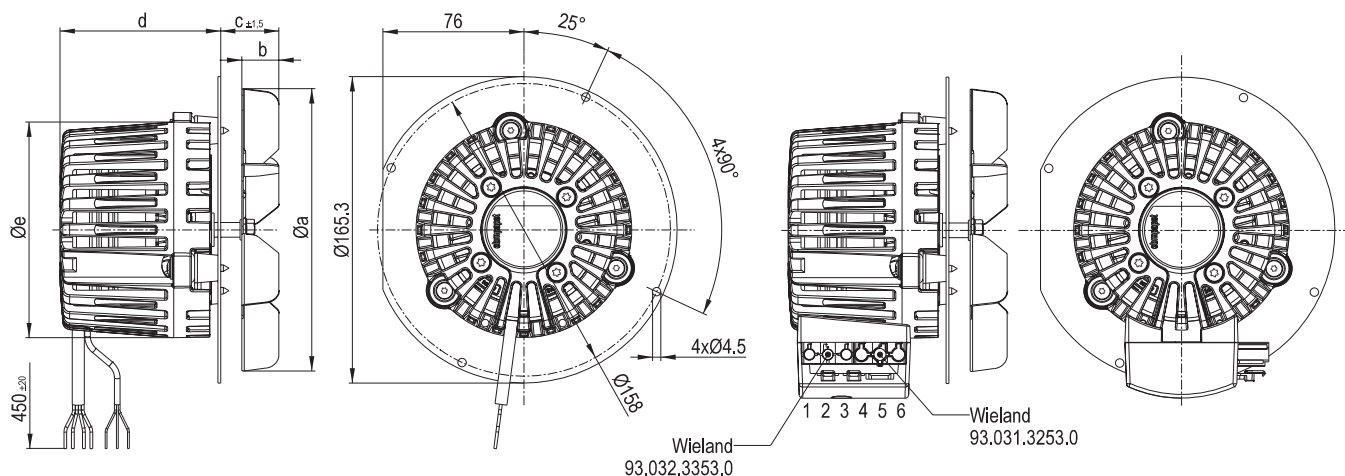

AC centrifugal fans (exhaust air)

for solid fuel heating systems, single inlet, Ø 150

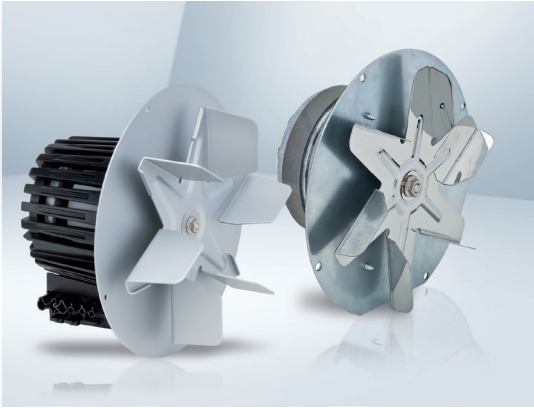

- **Material:** Impeller: Corrosion resistant sheet steel
- **Direction of rotation:** Clockwise, seen on impeller
- **Type of protection:** IP 44, depending on installation and position
- **Insulation class:** "F"
- **Mounting position:** Any
- **Condensate discharges:** None
- **Mode of operation:** Continuous operation (S1)
- **Bearings:** Maintenance-free ball bearings
- **Max. exhaust gas temperature:** Continuous operation 250°C

Nominal data		Curve	Nominal voltage	Frequency	Air flow	Speed/rpm	Max. input power	Max. current draw	Capacitor	Sound pressure level	Perm. amb. temp.	Mass	Electr. connection
Type	Motor	VAC	Hz	m ³ /h	rpm	W	A	µF/VDB	dB(A)	°C	kg	p. 98, 99	
R2E 150-AP82 -**	M2E 068-CF	Ⓐ	230	50	220	2750	44	0,27	1,0/400	---	-25..+40	1,8	A1), D)
R2E 150-AK82 -**		Ⓐ	230	50	220	2750	44	0,27	1,0/400	---	-25..+70	2,0	

subject to alterations

Curves:

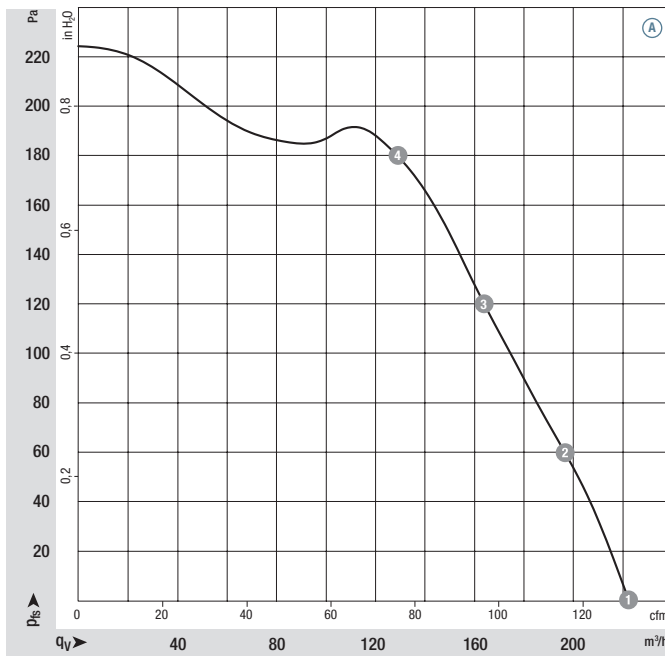

	n rpm	P _{ed} W	I A	L _{pA} dB(A)
Ⓐ 1	2750	44	0,27	---
Ⓐ 2	2760	44	0,27	---
Ⓐ 3	2770	43	0,26	---
Ⓐ 4	2795	41	0,26	---

Air performance measured as per: ISO 5801, Installation category A, without scroll housing without protection against accidental contact. Suction-side noise levels: L_{wA} as per ISO 13347, L_{pA} measured at 1 m distance to fan axis. The acoustic values given are only valid under the measurement conditions listed and may vary depending on the installation situation. With any deviation to the standard setup, the specific values have to be checked and reviewed once installed or fitted! For detailed information see page 100 ff.

- **Motor protection:** TOP wired internally
- **Touch current:** < 0,75 mA acc. to IEC 60990 (test circuit, illustration 4)
- **Standard:** Speed monitoring via Hall IC
- **Cable exit:** Variable
- **Protection class:** I (if customer has provided connection for protective earth)
- **Product conforming to standards:** EN 60335-1, CE
- **Approvals:** UL, CSA, CCC, GOST are applied for
- **Optional:** Additional shaft seal made from ceramic (see p. 94)

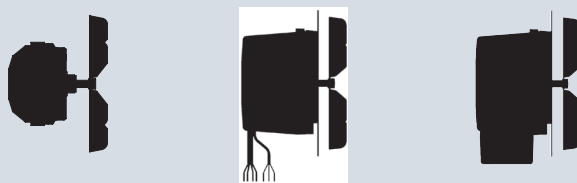

Selection

Dimensions

Type	without motor protection hood	Cable design	Plug design	a	b	c	d	e
R2E 150-AP82 -**	---	R2E 150-AP82 -01	R2E 150-AP82 -05	148	42	53,5	108	119
R2E 150-AK82 -**	R2E 150-AK82 -01	---	---	---	---	---	---	---

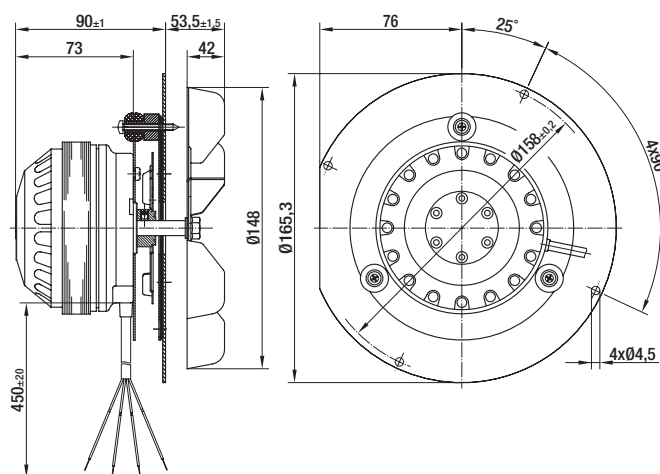

Connection:

- 1 = L (blue)
- 2 = PE (green/yellow)
- 3 = N (black)
- 4 = GND (black)
- 5 = OUT (white)
- 6 = VCC (red)

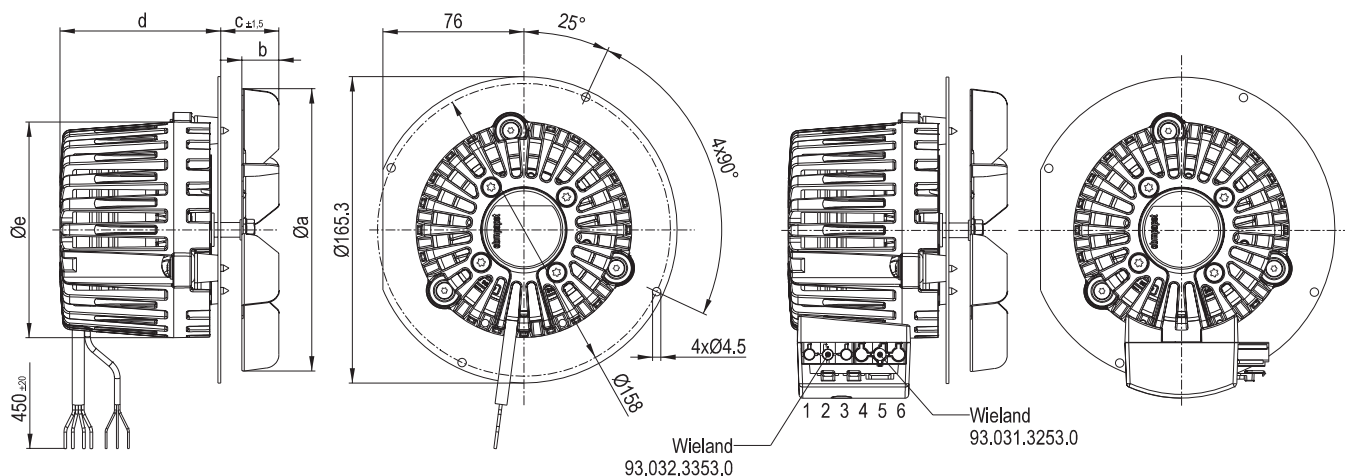

AC centrifugal fans (exhaust air)

for solid fuel heating systems, special designs, Ø 150/160

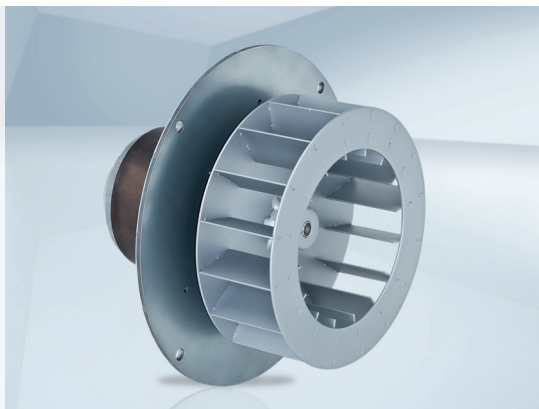

- **Material:** Impeller: sheet steel
- **Direction of rotation:** Clockwise, seen on impeller
- **Type of protection:** IP 44
- **Insulation class:** "F"
- **Mounting position:** Any
- **Condensate discharges:** None
- **Mode of operation:** Continuous operation (S1)
- **Bearings:** Maintenance-free ball bearings
- **Max. exhaust gas temperature:** Continuous operation 250°C

Nominal data		Curve	Nominal voltage		Frequency	Air flow	Speed/rpm	Max. input power	Max. current draw	Capacitor	Sound pressure level	Zul. Umgeb.temp. (1)	Mass	Electr. connection
Type	Motor	VAC	Hz	m ³ /h	rpm	W	A	µF/VDB	dB(A)	°C	kg	p. 98, 99		
R2E 160-BG34 -**	M2E 068-DF	Ⓐ	230	50	285	2730	63	0,28	1,5/400	64	-25..+90	3,8	A1), D)	
R2E 150-AL06 -**	M2E 074-DF	Ⓑ	230	50	460	2720	107	0,50	3,0/400	67	-25..+85	4,0		

subject to alterations

Curves:

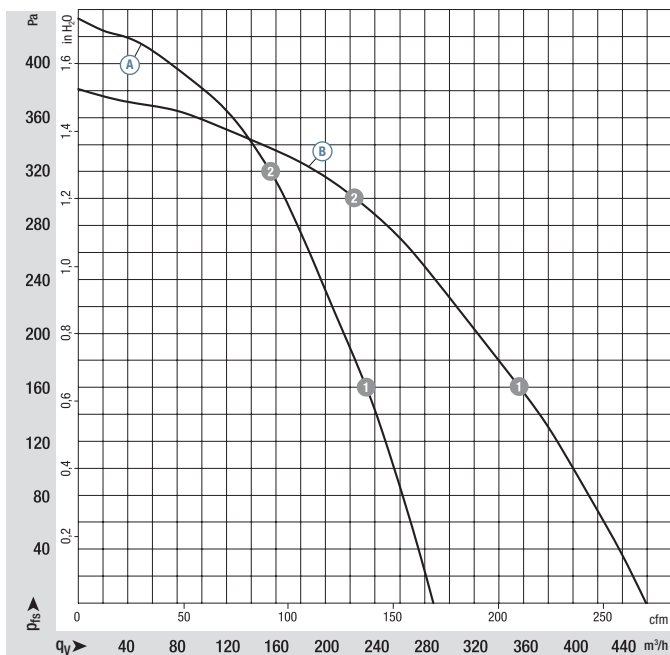

	n rpm	P _{ed} W	I A	L _{pA} dB(A)
Ⓐ 1	2780	57	0,26	---
Ⓐ 2	2830	48	0,22	---
Ⓑ 1	2785	78	0,35	---
Ⓑ 2	2840	65	0,30	---

Air performance measured as per: ISO 5801, Installation category A, with scroll housing without protection against accidental contact. Suction-side noise levels: L_w as per ISO 13347, L_{pA} measured at 1 m distance to fan axis. The acoustic values given are only valid under the measurement conditions listed and may vary depending on the installation situation. With any deviation to the standard setup, the specific values have to be checked and reviewed once installed or fitted! For detailed information see page 100 ff.

- **Motor protection:** TOP wired internally
- **Touch current:** < 0,75 mA acc. to IEC 60990 (test circuit, illustration 4)
- **Standard:** Speed monitoring via Hall IC
- **Cable exit:** Variable
- **Protection class:** I
- **Product conforming to standards:** EN 60335-1, CE
- **Approvals:** UL, CSA, CCC, GOST are applied for
- **Optional:** Additional shaft seal made from ceramic (see p. 94)



Selection

Dimensions

Type	without motor protection hood	with motor protection hood	a	b	d	e	f	g	h
R2E 160-BG34 -**	R2E 160-BG34 -01	R2E 160-BG34 -05	50	40	160	103	83	132	109
R2E 150-AL06 -**	R2E 150-AL06 -01	R2E 150-AL06 -05	84	74	150	135	110	144	146

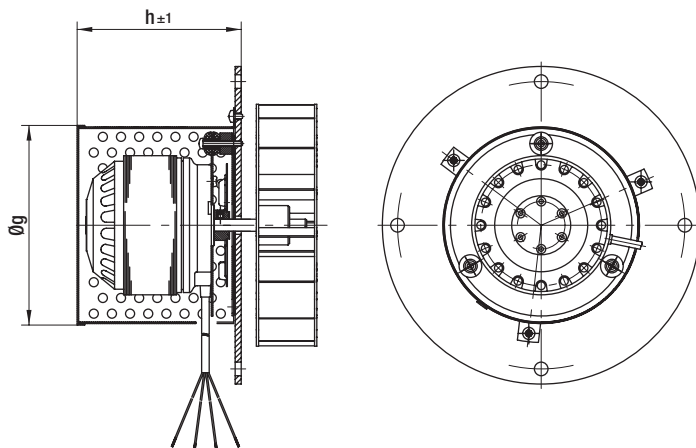
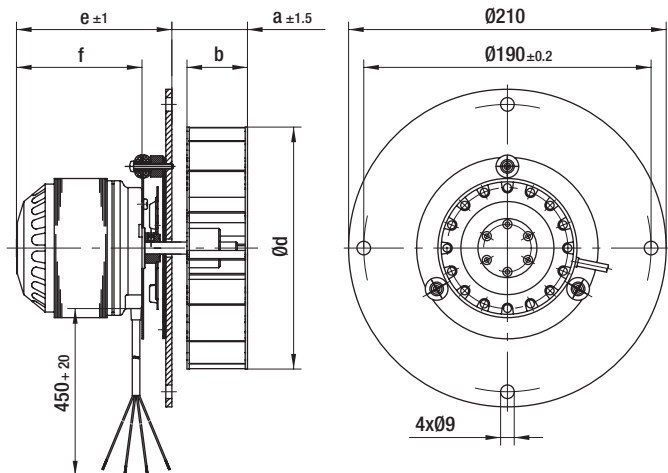

AC centrifugal fans (exhaust air)

for solid fuel heating systems, single inlet, Ø 160

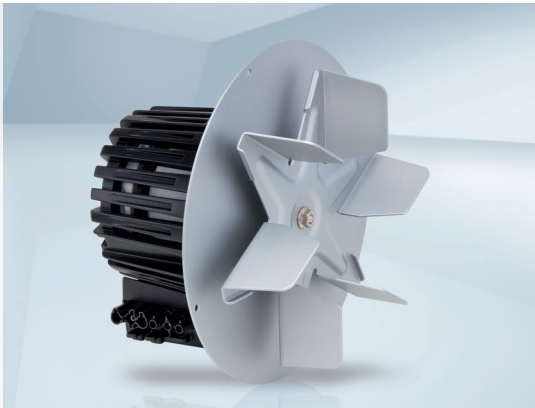

- **Material:** Impeller: Corrosion resistant sheet steel
- **Direction of rotation:** Clockwise, seen on impeller
- **Type of protection:** IP 44
- **Insulation class:** "F"
- **Mounting position:** Any
- **Condensate discharges:** None
- **Mode of operation:** Continuous operation (S1)
- **Bearings:** Maintenance-free ball bearings
- **Max. exhaust gas temperature:** Continuous operation 250°C

Nominal data		Curve	Nominal voltage	Frequency	Air flow	Speed/rpm	Max. input power	Max. current draw	Capacitor	Sound pressure level	Perm. amb. temp.	Mass	Electr. connection
Type	Motor	VAC	Hz	m ³ /h	rpm	W	A	µF/VDB	dB(A)	°C	kg	p. 98, 99	
R2E 160-BL32 -**	M2E 068-CF	Ⓐ 230	50	310	2700	---	---	1,0/400	---	-25..+45	1,8	A1), D)	

subject to alterations

Curves:

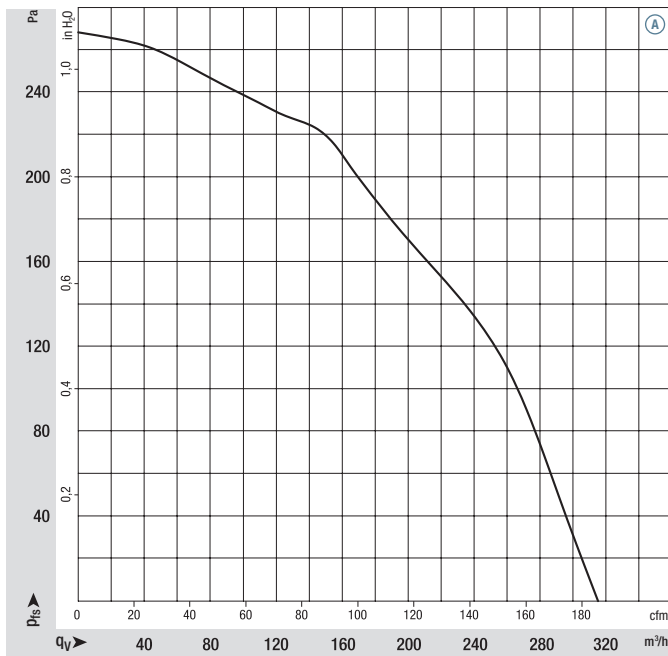

Air performance measured as per: ISO 5801, Installation category A, without scroll housing without protection against accidental contact. Suction-side noise levels: L_{wA} as per ISO 13347, L_{pA} measured at 1 m distance to fan axis. The acoustic values given are only valid under the measurement conditions listed and may vary depending on the installation situation. With any deviation to the standard setup, the specific values have to be checked and reviewed once installed or fitted! For detailed information see page 100 ff.

- **Motor protection:** TOP wired internally
- **Touch current:** < 0,75 mA acc. to IEC 60990 (test circuit, illustration 4)
- **Standard:** Speed monitoring via Hall IC
- **Optional:** also possible, without protection hood
- **Cable exit:** Variable
- **Protection class:** I
- **Product conforming to standards:** EN 60335-1, CE
- **Approvals:** UL, CSA, CCC, GOST are applied for
- **Optional:** Additional shaft seal made from ceramic (see p. 94)



Selection

Dimensions

Type	Cable design	Plug design	a	b	c	d	e
R2E 160-BL32 -**	R2E 160-BL32 -01	R2E 160-BL32 -05	160	40	49,5	108	119

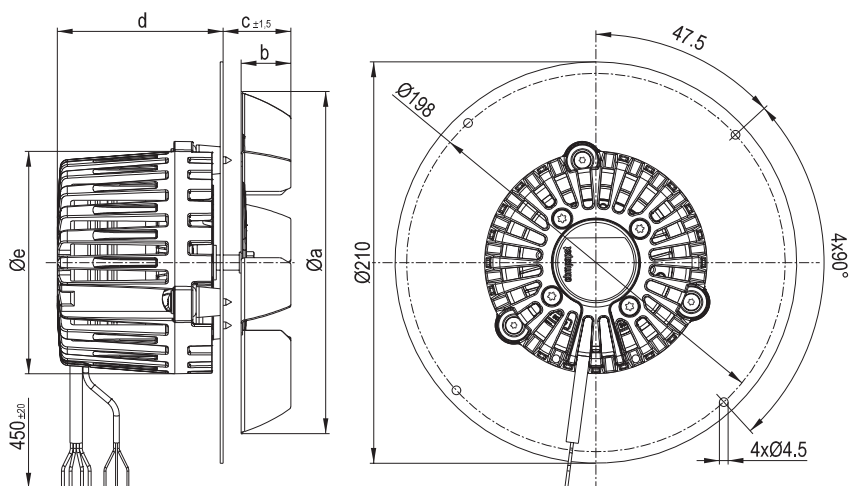

Connection:

- 1 = L (blue)
- 2 = PE (green/yellow)
- 3 = N (black)
- 4 = GND (black)
- 5 = OUT (white)
- 6 = VCC (red)

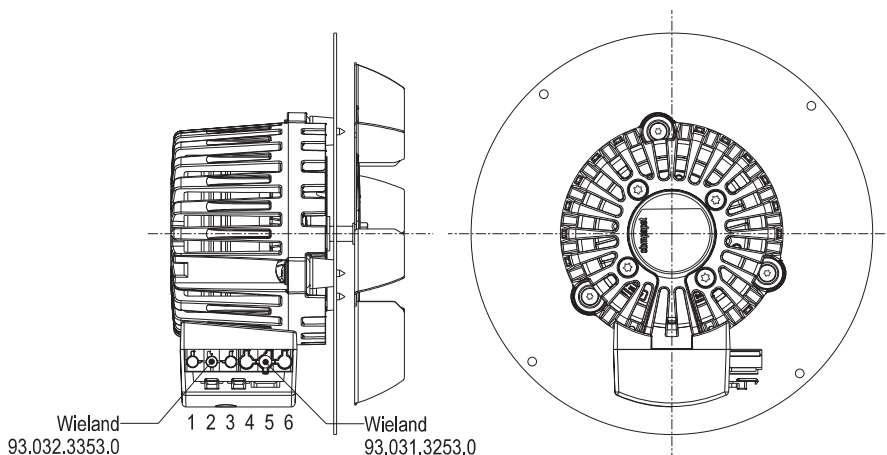

AC centrifugal fans (exhaust air)

for solid fuel heating systems, single inlet, Ø 180

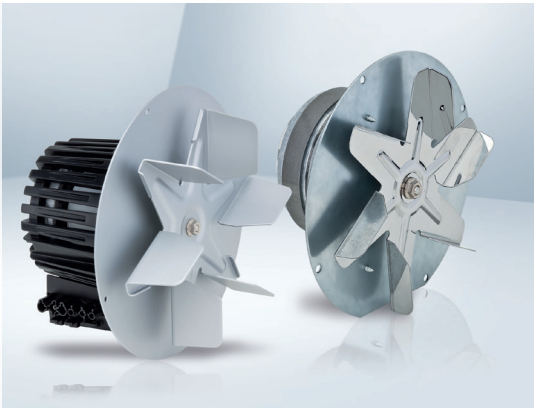

- **Material:** Impeller: Corrosion resistant sheet steel
- **Direction of rotation:** Clockwise, seen on impeller
- **Type of protection:** IP 44, depending on installation and position
- **Insulation class:** "F"
- **Mounting position:** Any
- **Condensate discharges:** None
- **Mode of operation:** Continuous operation (S1)
- **Bearings:** Maintenance-free ball bearings
- **Max. exhaust gas temperature:** Continuous operation 250°C

Nominal data		Curve	Nominal voltage	Frequency	Air flow	Speed/rpm	Max. input power	Max. current draw	Capacitor	Sound pressure level	Perm. amb. temp.	Mass	Electr. connection
Type	Motor	VAC	Hz	m ³ /h	rpm	W	A	µF/VDB	dB(A)	°C	kg	p. 98, 99	
R2E 180-CT91 -**	M2E 068-BF	Ⓐ	230	50	255	1850	38	0,18	1,0/400	---	-25..+60	1,7	A1), D)
R2E 180-CF91 -**		Ⓐ	230	50	255	1850	38	0,18	1,0/400	---	-25..+85	1,9	

subject to alterations

Curves:

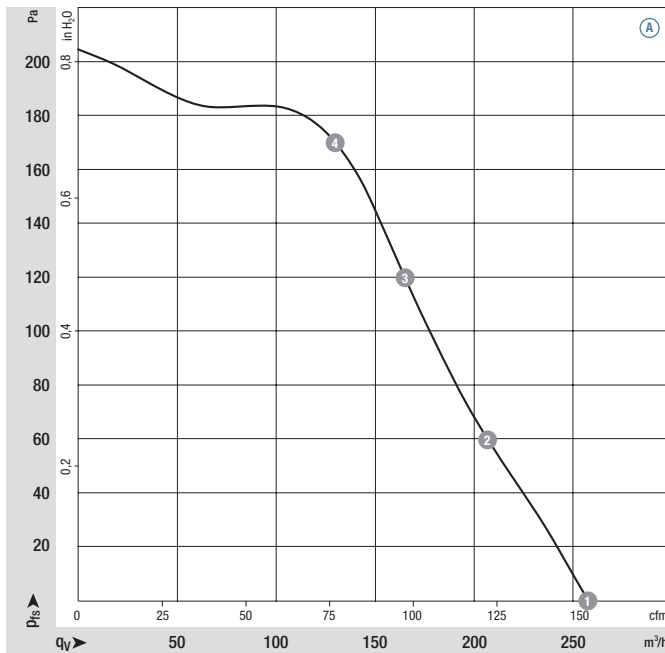

	n rpm	P _{ed} W	I A	L _{pA} dB(A)
Ⓐ 1	1850	38	0,18	---
Ⓐ 2	1840	38	0,16	---
Ⓐ 3	1940	37	0,16	---
Ⓐ 4	2110	35	0,15	---

Air performance measured as per: ISO 5801, Installation category A, without scroll housing without protection against accidental contact. Suction-side noise levels: L_{wA} as per ISO 13347, L_{pA} measured at 1 m distance to fan axis. The acoustic values given are only valid under the measurement conditions listed and may vary depending on the installation situation. With any deviation to the standard setup, the specific values have to be checked and reviewed once installed or fitted! For detailed information see page 100 ff.

- **Motor protection:** TOP wired internally
- **Touch current:** < 0,75 mA acc. to IEC 60990 (test circuit, illustration 4)
- **Standard:** Speed monitoring via Hall IC
- **Cable exit:** Variable
- **Protection class:** I
- **Product conforming to standards:** EN 60335-1, CE
- **Approvals:** UL, CSA, CCC, GOST are applied for
- **Optional:** Additional shaft seal made from ceramic (see p. 94)

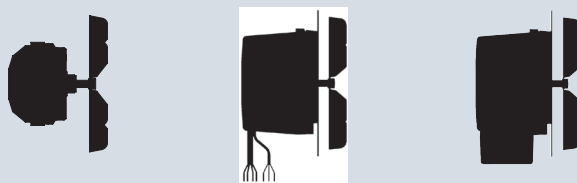

Selection

Dimensions

Type	without motor protection hood	Cable design	Plug design	a	b	c	d	e
R2E 180-CT91 -**	---	R2E 180-CT91 -01	R2E 180-CT91 -05	180	26	44,5	108	119
R2E 180-CF91 -**	R2E 180-CF91 -01	---	---	---	---	---	---	---

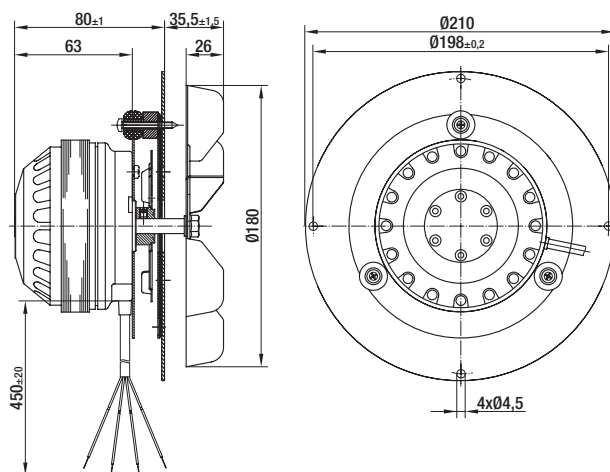

Connection:

- 1 = L (blue)
- 2 = PE (green/yellow)
- 3 = N (black)
- 4 = GND (black)
- 5 = OUT (white)
- 6 = VCC (red)

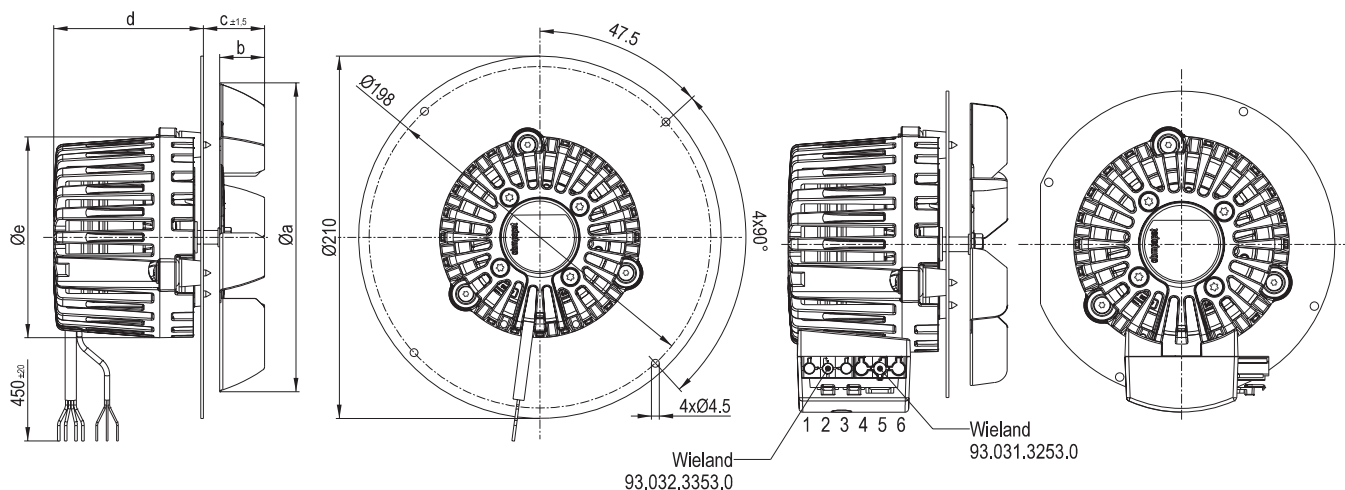

AC centrifugal fans (exhaust air)

for solid fuel heating systems, single inlet, Ø 180

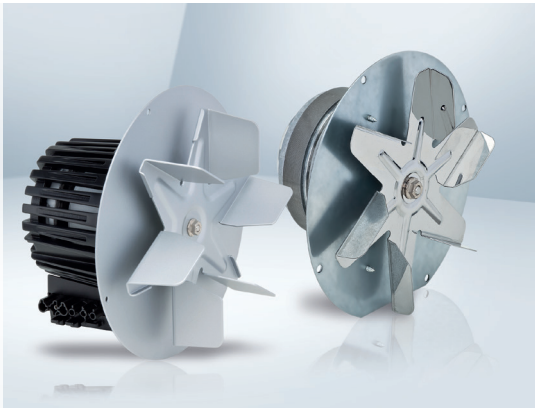

- **Material:** Impeller: Corrosion resistant sheet steel
- **Direction of rotation:** Clockwise, seen on impeller
- **Type of protection:** IP 44, depending on installation and position
- **Insulation class:** "F"
- **Mounting position:** Any
- **Condensate discharges:** None
- **Mode of operation:** Continuous operation (S1)
- **Bearings:** Maintenance-free ball bearings
- **Max. exhaust gas temperature:** Continuous operation 250°C

Nominal data		Curve	Nominal voltage	Frequency	Air flow	Speed/rpm	Max. input power	Max. current draw	Capacitor	Sound pressure level	Perm. amb. temp.	Mass	Electr. connection
Type	Motor	VAC	Hz	m ³ /h	rpm	W	A	µF/VDB	dB(A)	°C	kg	p. 98, 99	
R2E 180-CV82 -**	M2E 068-CF	Ⓐ	230	50	420	2500	75	0,34	2,0/400	---	-25..+45	1,7	A1), D)
R2E 180-CG82 -**		Ⓐ	230	50	420	2500	75	0,34	2,0/400	---	-25..+60	2,3	

subject to alterations

Curves:

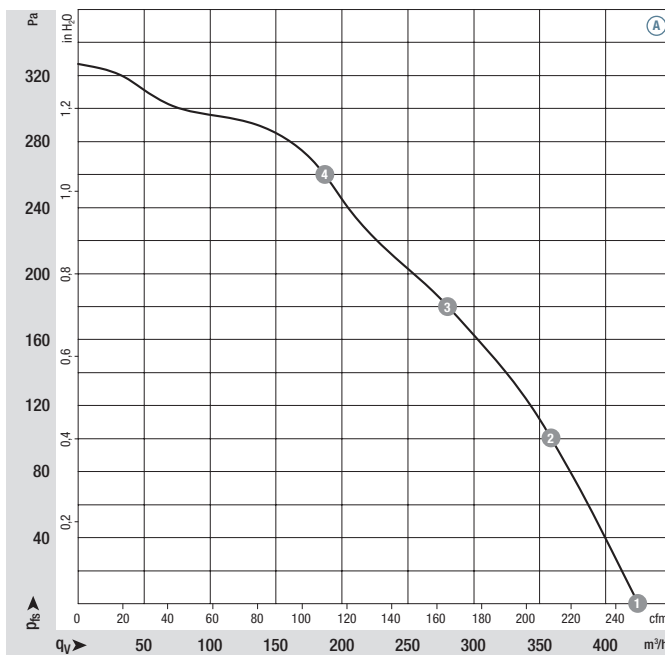

	n rpm	P _{ed} W	I A	L _{pA} dB(A)
Ⓐ 1	2500	75	0,34	---
Ⓐ 2	2490	74	0,33	---
Ⓐ 3	2520	72	0,32	---
Ⓐ 4	2585	67	0,30	---

Air performance measured as per: ISO 5801, Installation category A, without scroll housing without protection against accidental contact. Suction-side noise levels: L_{wA} as per ISO 13347, L_{pA} measured at 1 m distance to fan axis. The acoustic values given are only valid under the measurement conditions listed and may vary depending on the installation situation. With any deviation to the standard setup, the specific values have to be checked and reviewed once installed or fitted! For detailed information see page 100 ff.

- **Motor protection:** TOP wired internally
- **Touch current:** < 0,75 mA acc. to IEC 60990 (test circuit, illustration 4)
- **Standard:** Speed monitoring via Hall IC
- **Cable exit:** Variable
- **Protection class:** I
- **Product conforming to standards:** EN 60335-1, CE
- **Approvals:** UL, CSA, CCC, GOST are applied for
- **Optional:** Additional shaft seal made from ceramic (see p. 94)

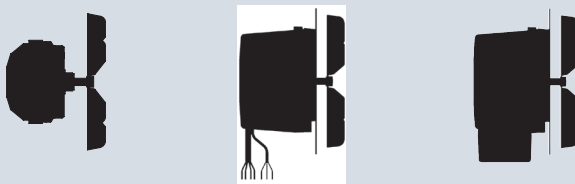

Selection

Dimensions

Type	without motor protection hood	Cable design	Plug design	a	b	c	d	e
R2E 180-CV82 -**	---	R2E 180-CV82 -01	R2E 180-CV82 -05	180	45	54,5	108	119
R2E 180-CG82 -**	R2E 180-CG82 -01	---	---	---	---	---	---	---

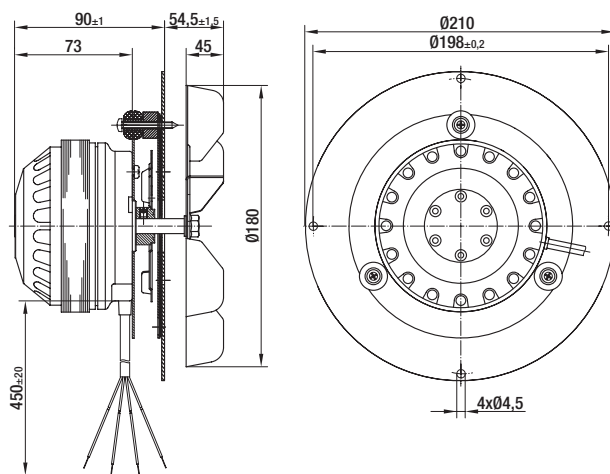

Connection:

- 1 = L (blue)
- 2 = PE (green/yellow)
- 3 = N (black)
- 4 = GND (black)
- 5 = OUT (white)
- 6 = VCC (red)

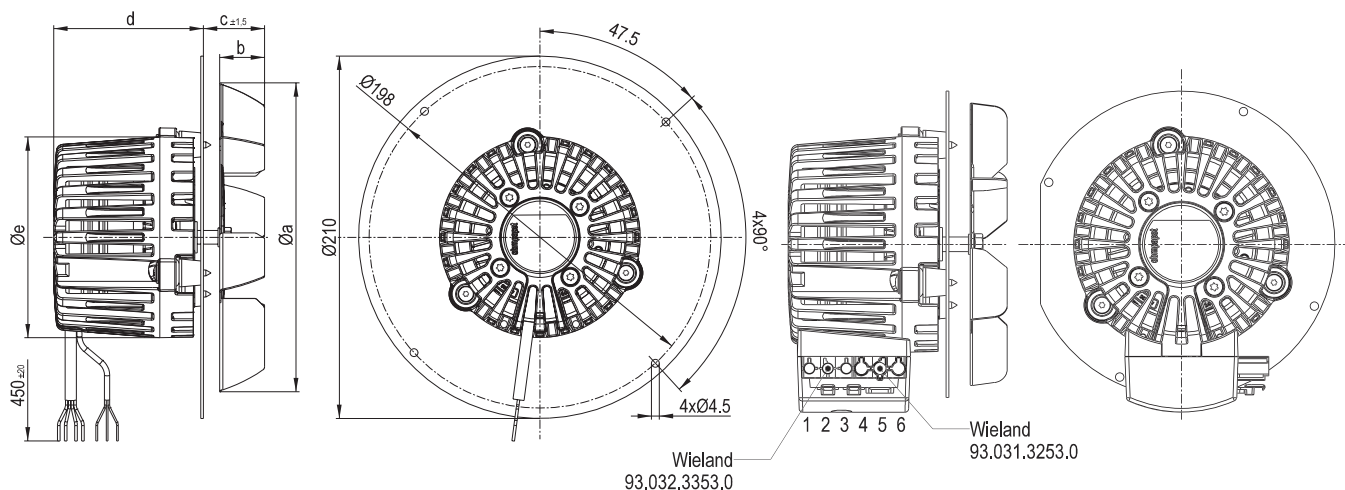

AC centrifugal fans (exhaust air)

for solid fuel heating systems, single inlet, Ø 210

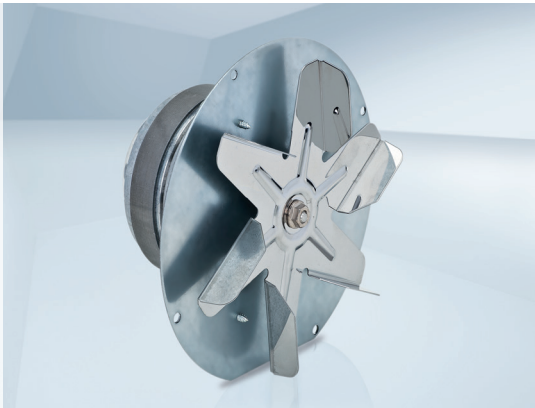

- **Material:** Impeller: Corrosion resistant sheet steel
- **Direction of rotation:** Clockwise, seen on impeller
- **Type of protection:** IP 44
- **Insulation class:** "F"
- **Mounting position:** Any
- **Condensate discharges:** None
- **Mode of operation:** Continuous operation (S1)
- **Bearings:** Maintenance-free ball bearings
- **Max. exhaust gas temperature:** Continuous operation 250°C

Nominal data		Curve	Nominal voltage	Frequency	Air flow	Speed/rpm	Max. input power	Max. current draw	Capacitor	Sound pressure level	Zul. Umgeb.temp. (1)	Mass	Electr. connection
Type	Motor	VAC	Hz	m ³ /h	rpm	W	A	µF/VDB	dB(A)	°C	kg	p. 98, 99	
R2E 210-AA34 -**	M2E 068-DF	Ⓐ	230	50	520	2500	110	0,49	2,0/450	---	-25..+90	2,9	A1), D)
R2E 210-AB34 -**		Ⓑ	230	50	600	2400	125	0,56	2,5/400	---	-25..+70	3,1	

subject to alterations

(1) measured with motor protection hood: Ⓐ = -25..+70°C, Ⓑ = -25..+45°C

Curves:

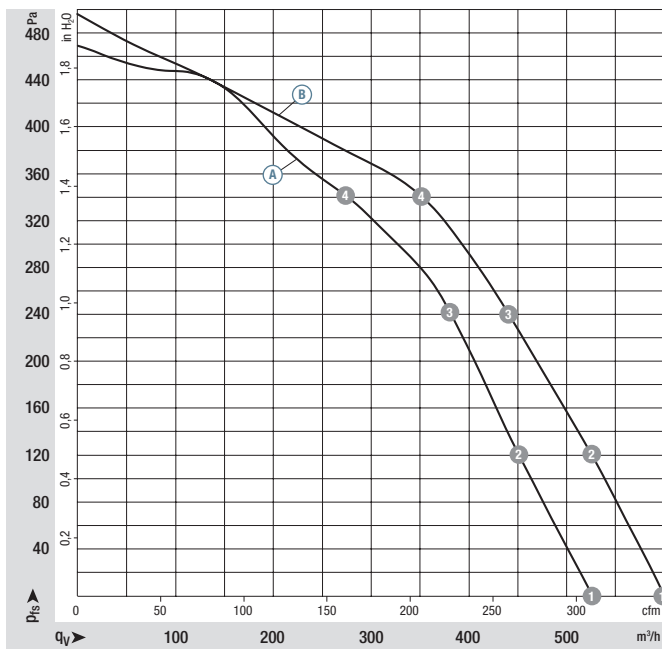

	n rpm	P _{ed} W	I A	L _{pA} dB(A)
Ⓐ ①	2500	110	0,49	---
Ⓐ ②	2495	109	0,48	---
Ⓐ ③	2550	102	0,44	---
Ⓐ ④	2660	87	0,38	---
Ⓑ ①	2400	125	0,56	---
Ⓑ ②	2420	125	0,54	---
Ⓑ ③	2455	122	0,53	---
Ⓑ ④	2545	111	0,48	---

Air performance measured as per: ISO 5801, Installation category A, without scroll housing without protection against accidental contact. Suction-side noise levels: L_{wA} as per ISO 13347, L_{pA} measured at 1 m distance to fan axis. The acoustic values given are only valid under the measurement conditions listed and may vary depending on the installation situation. With any deviation to the standard setup, the specific values have to be checked and reviewed once installed or fitted! For detailed information see page 100 ff.

- **Motor protection:** TOP wired internally
- **Touch current:** < 0,75 mA acc. to IEC 60990 (test circuit, illustration 4)
- **Standard:** Speed monitoring via Hall IC
- **Cable exit:** Variable
- **Protection class:** I
- **Product conforming to standards:** EN 60335-1, CE
- **Approvals:** UL, CSA, CCC, GOST are applied for
- **Optional:** Additional shaft seal made from ceramic (see p. 94)



Selection

Dimensions

Type	without motor protection hood	with motor protection hood	a	b
R2E 210-AA34 -**	R2E 210-AA34 -01	R2E 210-AA34 -05	39,5	30
R2E 210-AB34 -**	R2E 210-AB34 -01	R2E 210-AB34 -05	54,5	45

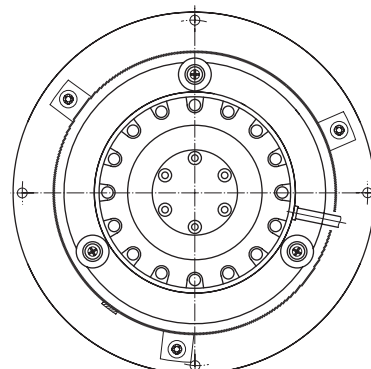
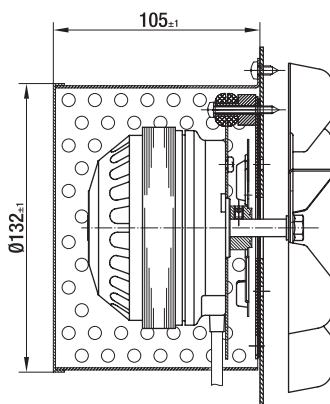
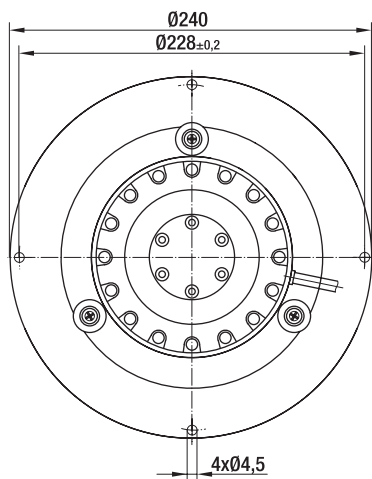
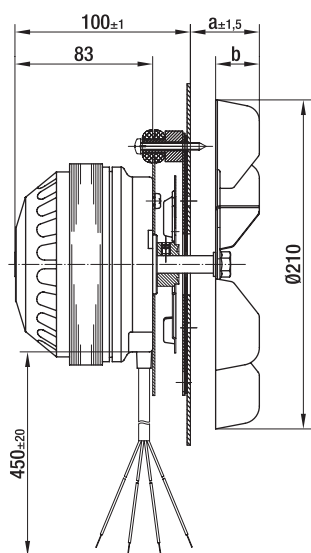

AC centrifugal fans (exhaust air)

for solid fuel heating systems, single inlet, Ø 250

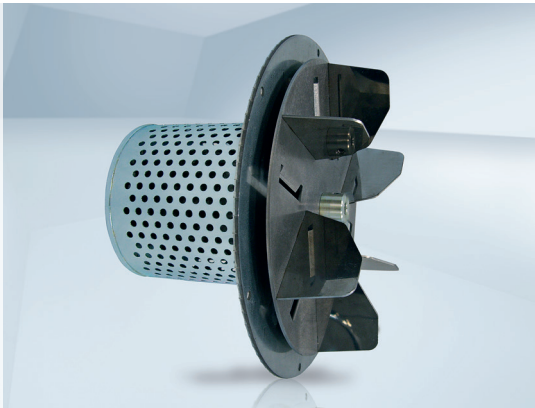

- **Material:** Impeller: Corrosion resistant sheet steel
- **Direction of rotation:** Clockwise, seen on impeller
- **Type of protection:** IP 44, depending on installation and position
- **Insulation class:** "F"
- **Mounting position:** Any
- **Condensate discharges:** None
- **Mode of operation:** Continuous operation (S1)
- **Bearings:** Maintenance-free ball bearings
- **Max. exhaust gas temperature:** Continuous operation 250°C

Nominal data

Type	Motor	Curve	Nominal voltage	Frequency	Air flow	Speed/rpm	Max. input power	Max. current draw	Capacitor	Sound pressure level	Perm. amb. temp.	Mass	Electr. connection
		VAC	Hz	m ³ /h	rpm	W	A	µF/VDB	dB(A)	°C	kg		
R2E 250-BE03 -**	M2E 074-EI	Ⓐ	230	50	1010	2500	260	1,15	7,0/400	---	-25..+50	8,1	p. 98, 99 A1), D)

subject to alterations

Curves:

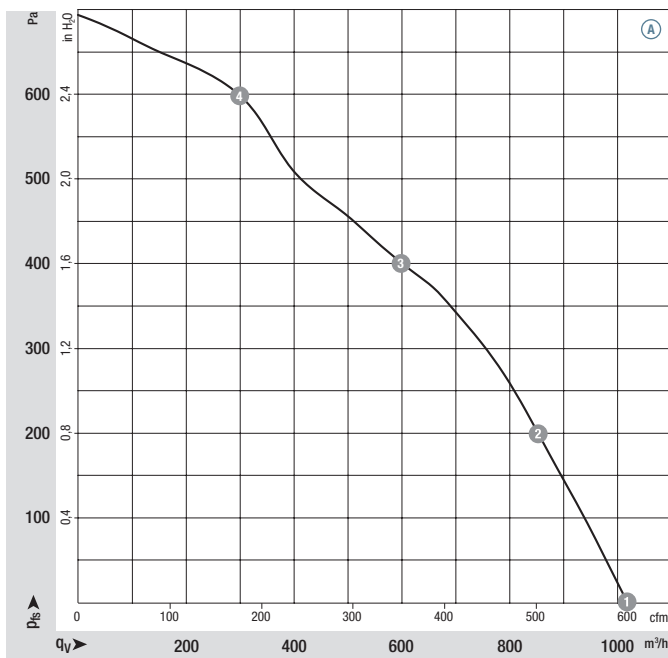

	n rpm	P _{ed} W	I A	L _{pA} dB(A)
Ⓐ 1	2500	260	1,15	---
Ⓐ 2	2540	258	1,13	---
Ⓐ 3	2590	243	1,06	---
Ⓐ 4	2700	204	0,89	---

Air performance measured as per: ISO 5801, Installation category A, without scroll housing without protection against accidental contact. Suction-side noise levels: L_{wA} as per ISO 13347, L_{pA} measured at 1 m distance to fan axis. The acoustic values given are only valid under the measurement conditions listed and may vary depending on the installation situation. With any deviation to the standard setup, the specific values have to be checked and reviewed once installed or fitted! For detailed information see page 100 ff.

- **Motor protection:** TOP wired internally
- **Touch current:** < 0,75 mA acc. to IEC 60990 (test circuit, illustration 4)
- **Standard:** Speed monitoring via Hall IC
- **Cable exit:** Variable
- **Protection class:** I (if customer has provided connection for protective earth)
- **Product conforming to standards:** EN 60335-1, CE
- **Approvals:** UL, CSA, CCC, GOST are applied for
- **Optional:** Additional shaft seal made from ceramic (see p. 94)



Selection

Type	with motor protection hood
R2E 250-BE03 -**	R2E 250-BE03 -10

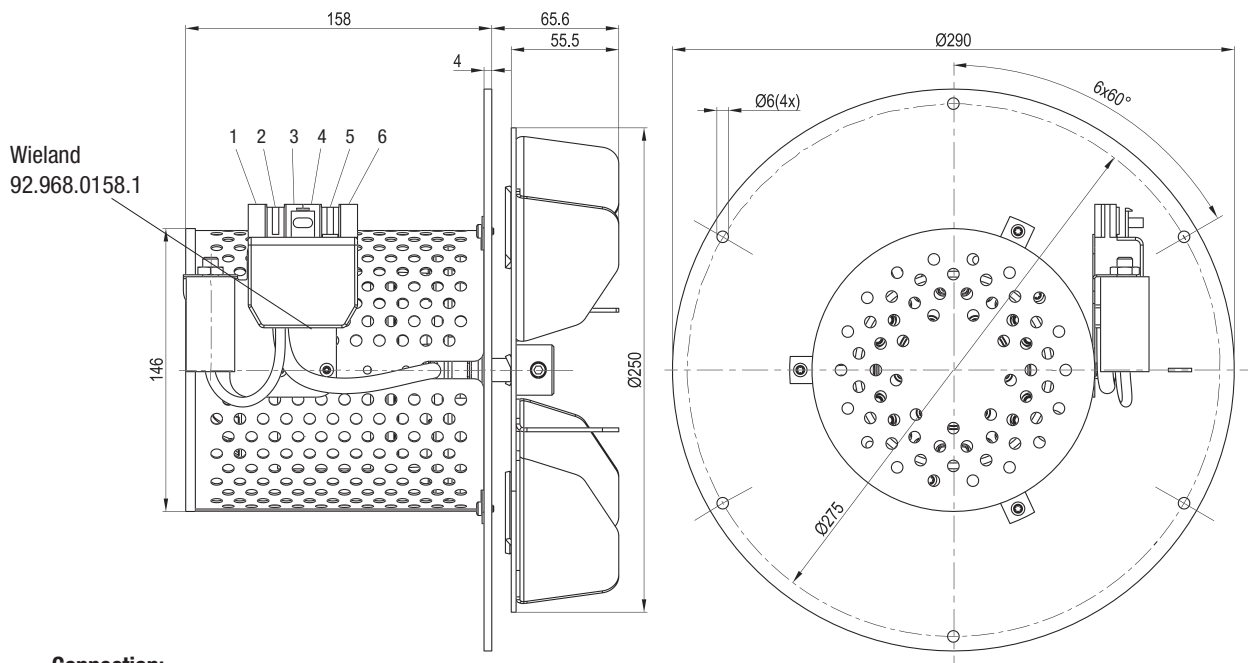

Connection:

- 1 = Hall-IC (black)
- 2 = Hall-IC (white)
- 3 = Hall-IC (red)
- 4 = black + capacitor
- 5 = green/yellow
- 6 = blue



EC/AC centrifugal blowers (exhaust air)



EC centrifugal blowers (exhaust air)

for solid fuel heating systems, single inlet, Ø 150

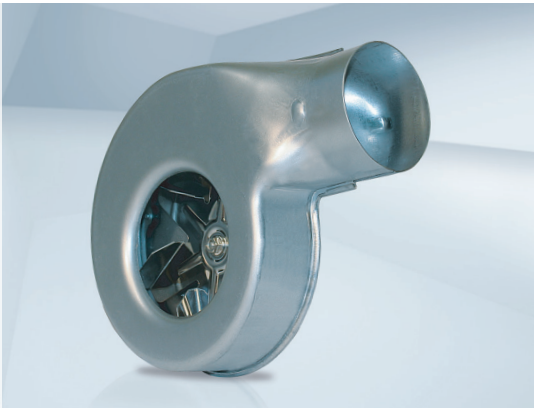

- **Material:** Impeller: Corrosion resistant sheet steel
Housing: Hot-dip aluminised sheet steel
- **Direction of rotation:** Clockwise, seen on impeller
- **Type of protection:** IP 54
- **Insulation class:** "B"
- **Mounting position:** Any
- **Condensate discharges:** None, open rotor
- **Mode of operation:** Continuous operation (S1)
- **Bearings:** Maintenance-free ball bearings
- **Max. exhaust gas temperature:** Continuous operation 250°C

Nominal data		Curve	Nominal voltage	Frequency	Air flow	Speed/rpm	Max. input power	Max. current draw	Sound pressure level	Perm. amb. temp.	Mass	Electr. connection
Type	Motor	VAC	Hz	m ³ /h	rpm	W	A	dB(A)	°C	kg	p. 96, 99	
G3G 150-DA03 -**	M3G 055-AI	Ⓐ 1~200-240	50/60	149	2535	16	0,17	66	-25..+60	2,0	H4), C)	

subject to alterations

Curves:

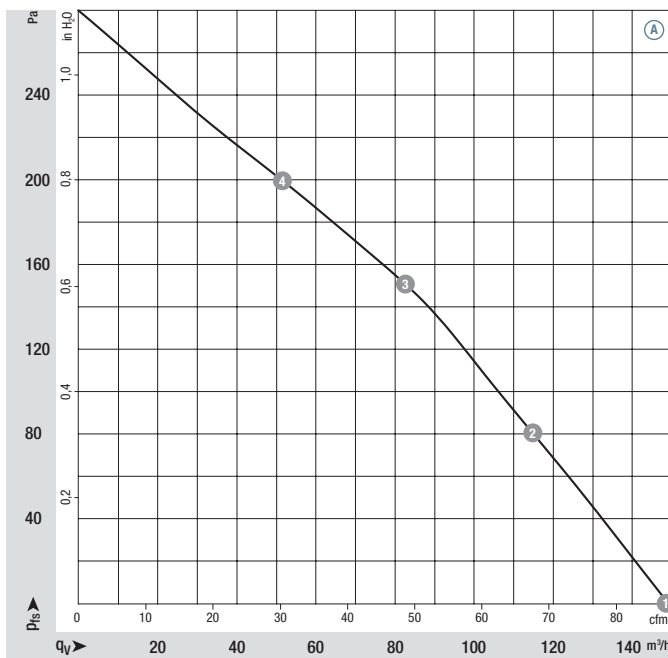

	n rpm	P _{ed} W	I A	L _{pA} dB(A)
Ⓐ 1	2535	16	0,17	---
Ⓐ 2	2545	16	0,17	---
Ⓐ 3	2585	15	0,16	---
Ⓐ 4	2635	14	0,16	---

Air performance measured as per: ISO 5801, Installation category A, with ebm-papst scroll housing without protection against accidental contact. Suction-side noise levels: L_w as per ISO 13347, L_{pA} measured at 1 m distance to fan axis. The acoustic values given are only valid under the measurement conditions listed and may vary depending on the installation situation. With any deviation to the standard setup, the specific values have to be checked and reviewed once installed or fitted! For detailed information see page 100 ff.

- **Technical features:** See electrical connections p. 96
- **EMC:** Interference emission acc. EN 61000-6-3
Interference immunity acc. EN 61000-6-2
Harmonics acc. EN 61000-3-2/3
- **Touch current:** < 3,5 mA acc. to IEC 60990 (test circuit, illustration 4)
- **Cable exit:** Variable
- **Protection class:** I (if customer has provided connection for protective earth)
- **Product conforming to standards:** EN 60335-1, CE
- **Approvals:** VDE, UL, CSA, CCC, GOST are applied for
- **Optional:** Additional shaft seal made from ceramic (see p. 94)

Selection

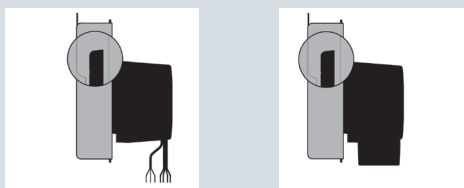

Type	Cable design	Plug design
G3G 150-DA03 -**	G3G 150-DA03 -01	G3G 150-DA03 -05

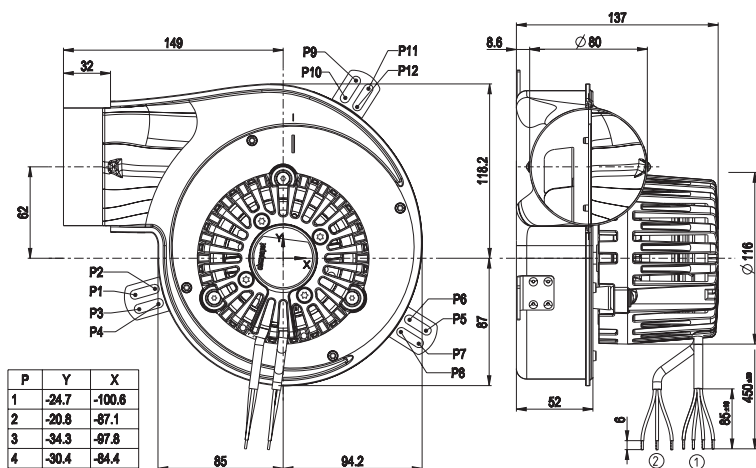

P	Y	X
1	-24.7	-100.6
2	-20.8	-87.1
3	-34.3	-87.8
4	-30.4	-84.4
5	-49.0	97.3
6	-41.6	85.4
7	-57.5	92.0
8	-50.1	80.1
9	120.3	49.4
10	108.5	41.9
11	114.9	57.8
12	103.1	50.3

Connection Z:

- 1 = N (blue)
- 2 = PE (green/yellow)
- 3 = L (black)
- 4 = 0-10V/PWM (yellow)
- 5 = GND (blue)
- 6 = Tacho (white)

P	Y	X
1	-24.7	-100.6
2	-20.8	-87.1
3	-34.3	-87.8
4	-30.4	-84.4
5	-49.0	97.3
6	-41.6	85.4
7	-57.5	92.0
8	-50.1	80.1
9	120.3	49.4
10	108.5	41.9
11	114.9	57.8
12	103.1	50.3

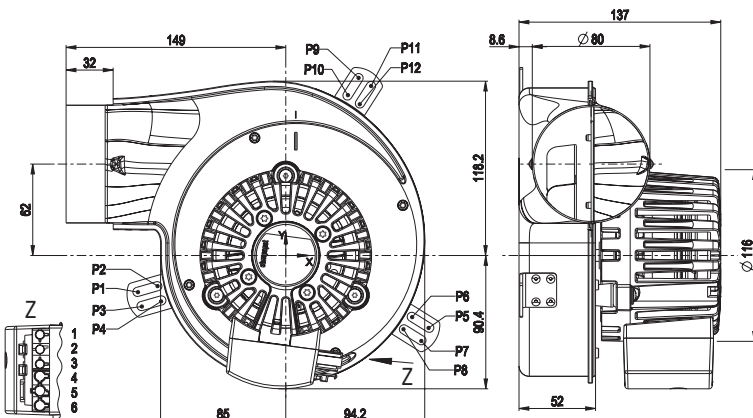

EC centrifugal blowers (exhaust air)

for solid fuel heating systems, single inlet, Ø 180



- **Material:** Impeller: Corrosion resistant sheet steel
Housing: Hot-dip aluminised sheet steel
- **Direction of rotation:** Clockwise, seen on impeller
- **Type of protection:** IP 54
- **Insulation class:** "B"
- **Mounting position:** Any
- **Condensate discharges:** None, open rotor
- **Mode of operation:** Continuous operation (S1)
- **Bearings:** Maintenance-free ball bearings
- **Max. exhaust gas temperature:** Continuous operation 250°C

Nominal data		Curve	Nominal voltage	Frequency	Air flow	Speed/rpm	Max. input power	Max. current draw	Sound pressure level	Perm. amb. temp.	Mass	Electr. connection
Type	Motor	VAC	Hz	m ³ /h	rpm	W	A	dB(A)	°C	kg	p. 96, 99	
G3G 180-FJ11 -**	M3G 055-CF	Ⓐ 1~200-240	50/60	340	2690	55	0,50	74	-25..+60	2,9	H4), C)	
G3G 180-GJ11 -**												

subject to alterations

Curves:

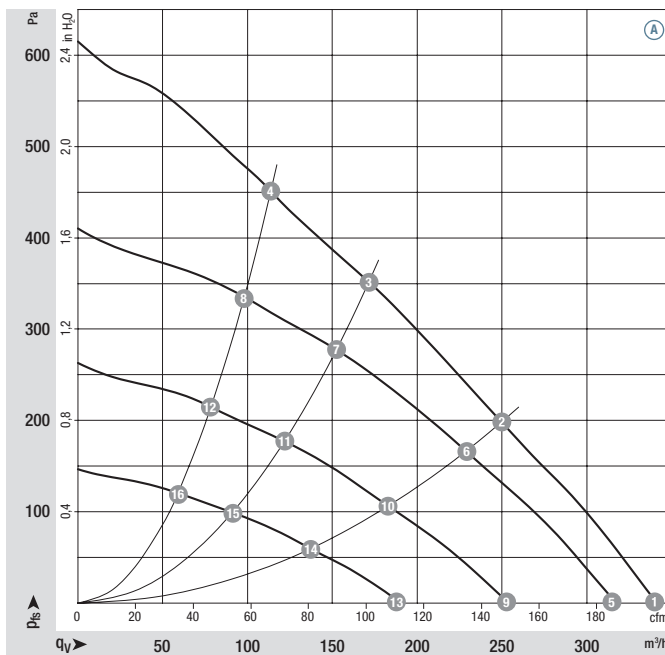

	n rpm	P _{ed} W	I A	L _{pA} dB(A)
Ⓐ 1	2690	55	0,50	74
Ⓐ 2	2725	52	0,48	70
Ⓐ 3	2810	46	0,44	66
Ⓐ 4	2895	39	0,38	64
Ⓐ 5	2500	44	0,40	72
Ⓐ 6	2500	40	0,37	67
Ⓐ 7	2500	32	0,31	63
Ⓐ 8	2500	25	0,25	61
Ⓐ 9	2000	22	0,21	66
Ⓐ 10	2000	20	0,19	62
Ⓐ 11	2000	16	0,16	57
Ⓐ 12	2000	13	0,13	55
Ⓐ 13	1500	9	0,09	59
Ⓐ 14	1500	9	0,08	55
Ⓐ 15	1500	7	0,07	50
Ⓐ 16	1500	5	0,05	48

Air performance measured as per: ISO 5801, Installation category A, with ebm-papst scroll housing without protection against accidental contact. Suction-side noise levels: L_{wa} as per ISO 13347, L_{pA} measured at 1 m distance to fan axis. The acoustic values given are only valid under the measurement conditions listed and may vary depending on the installation situation. With any deviation to the standard setup, the specific values have to be checked and reviewed once installed or fitted! For detailed information see page 100 ff.

- **Technical features:** See electrical connections p. 96
- **EMC:** Interference emission acc. EN 61000-6-3
Interference immunity acc. EN 61000-6-2
Harmonics acc. EN 61000-3-2/3
- **Touch current:** < 3,5 mA acc. to IEC 60990 (test circuit, illustration 4)
- **Cable exit:** Variable
- **Protection class:** I (if customer has provided connection for protective earth)
- **Product conforming to standards:** EN 60335-1, CE
- **Approvals:** VDE, UL, CSA, CCC, GOST are applied for
- **Optional:** Additional shaft seal made from ceramic (see p. 94)

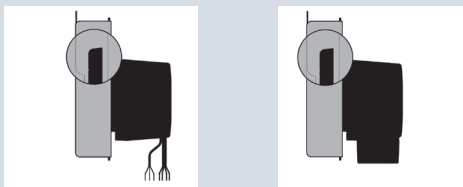
Selection			Dimensions
Type	Cable design	Plug design	a
G3G 180-FJ11 -**	G3G 180-FJ11 -01	G3G 180-FJ11 -05	186
G3G 180-GJ11 -**	G3G 180-GJ11 -01	G3G 180-GJ11 -05	223

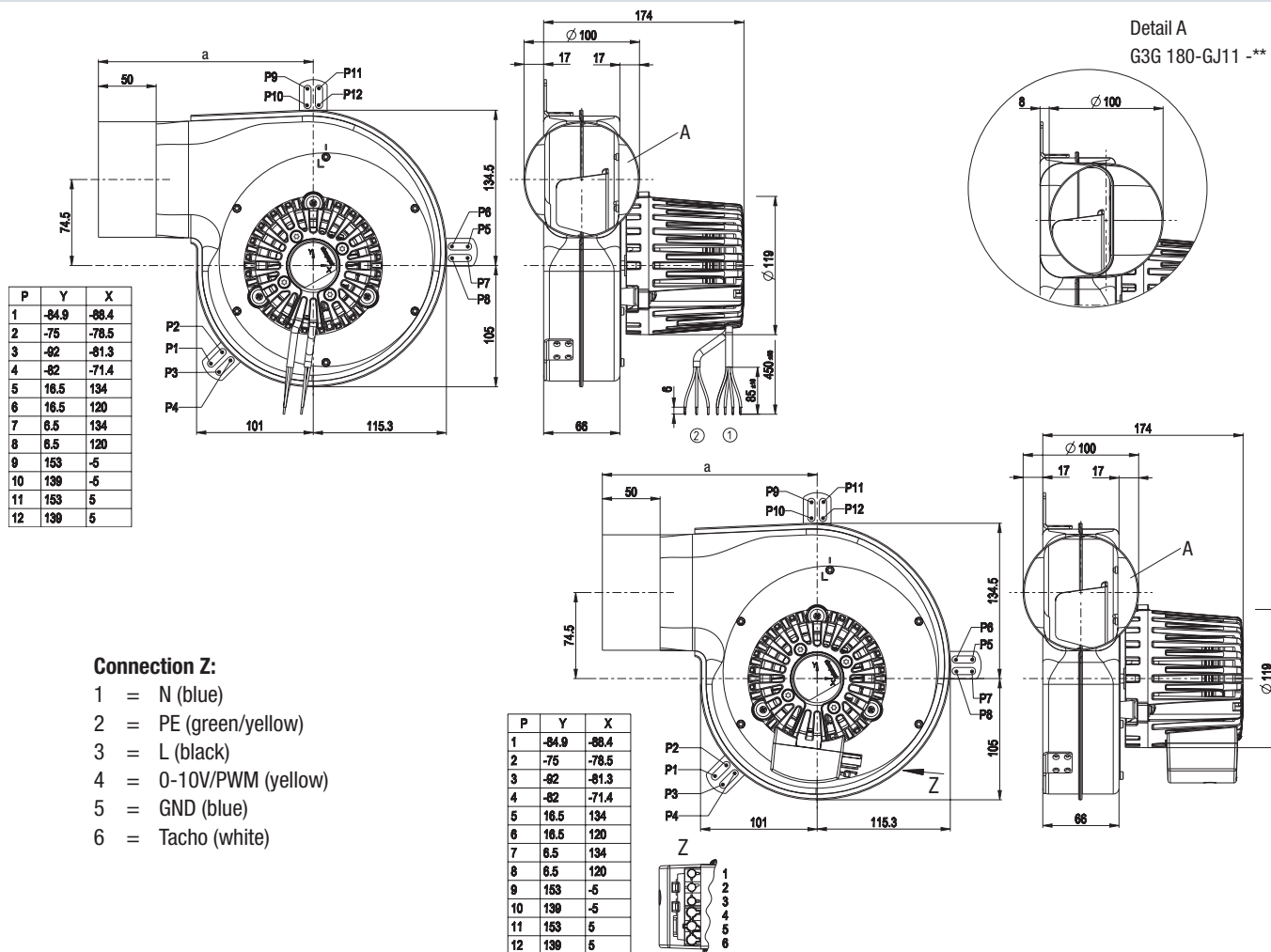

AC centrifugal blowers (exhaust air)

for solid fuel heating systems, single inlet, Ø 150

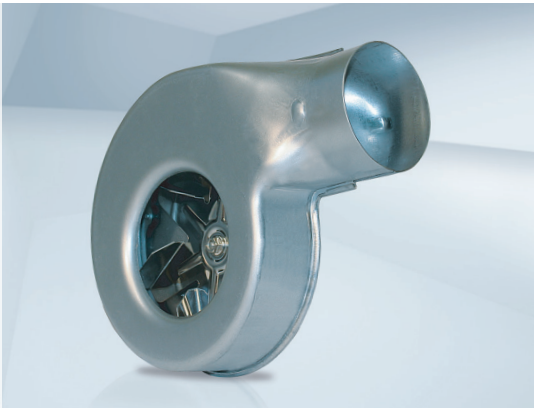

- **Material:** Impeller: Corrosion resistant sheet steel
Housing: Hot-dip aluminised sheet steel
- **Direction of rotation:** Clockwise, seen on impeller
- **Type of protection:** IP 44
- **Insulation class:** "F"
- **Mounting position:** Any
- **Condensate discharges:** None, open rotor
- **Mode of operation:** Continuous operation (S1)
- **Bearings:** Maintenance-free ball bearings
- **Max. exhaust gas temperature:** Continuous operation 250°C

Nominal data		Curve	Nominal voltage	Frequency	Air flow	Speed/rpm	Max. input power	Max. current draw	Capacitor	Sound pressure level	Perm. amb. temp.	Mass	Electr. connection
Type	Motor	VAC	Hz	m ³ /h	rpm	W	A	µF/VDB	dB(A)	°C	kg	p. 98, 99	
G2E 150-D091 -**	M2E 068-BF	Ⓐ 230	50	145	2480	30	0,14	1,0/400	---	-25..+50	2,3	A1), D)	
G2E 150-DN91 -**	M2E 068-BF	Ⓐ 230	50	145	2480	30	0,14	1,0/400	---	-25..+70	2,3	A1), D)	

subject to alterations

Curves:

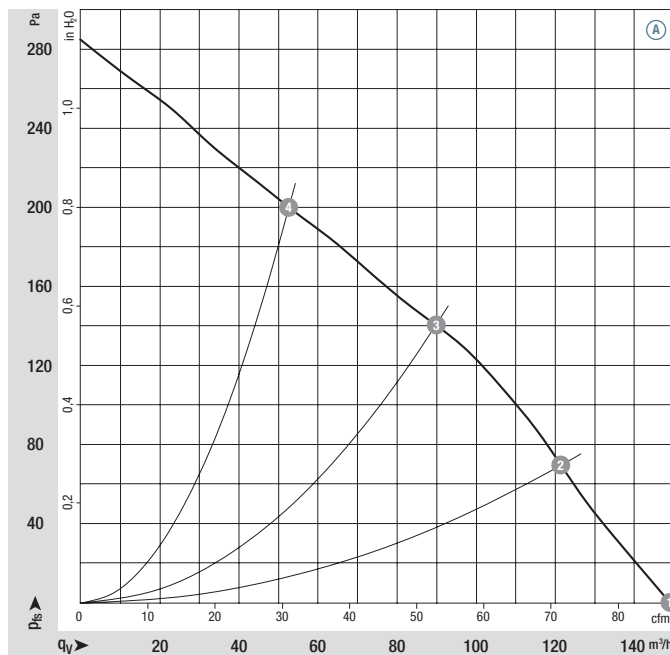

	n rpm	P _{ed} W	I A	L _{pA} dB(A)
Ⓐ 1	2480	30	0,14	---
Ⓐ 2	2505	30	0,13	---
Ⓐ 3	2560	29	0,13	---
Ⓐ 4	2620	28	0,12	---

Air performance measured as per: ISO 5801, Installation category A, with ebm-papst scroll housing without protection against accidental contact. Suction-side noise levels: L_w as per ISO 13347, L_{pA} measured at 1 m distance to fan axis. The acoustic values given are only valid under the measurement conditions listed and may vary depending on the installation situation. With any deviation to the standard setup, the specific values have to be checked and reviewed once installed or fitted! For detailed information see page 100 ff.

- **Motor protection:** TOP wired internally
- **Touch current:** < 0,75 mA acc. to IEC 60990 (test circuit, illustration 4)
- **Standard:** Speed monitoring via Hall IC
- **Protection class:** I
- **Product conforming to standards:** EN 60335-1, CE
- **Approvals:** UL, CSA, CCC, GOST are applied for
- **Optional:** Additional shaft seal made from ceramic (see p. 94)

Selection	Cable design	Plug design	Cable design without protection hood
G2E 150-D091 -**	G2E 150-D091 -01	G2E 150-D091 -05	---
G2E 150-DN91 -**	---	---	G2E 150-DN91 -01

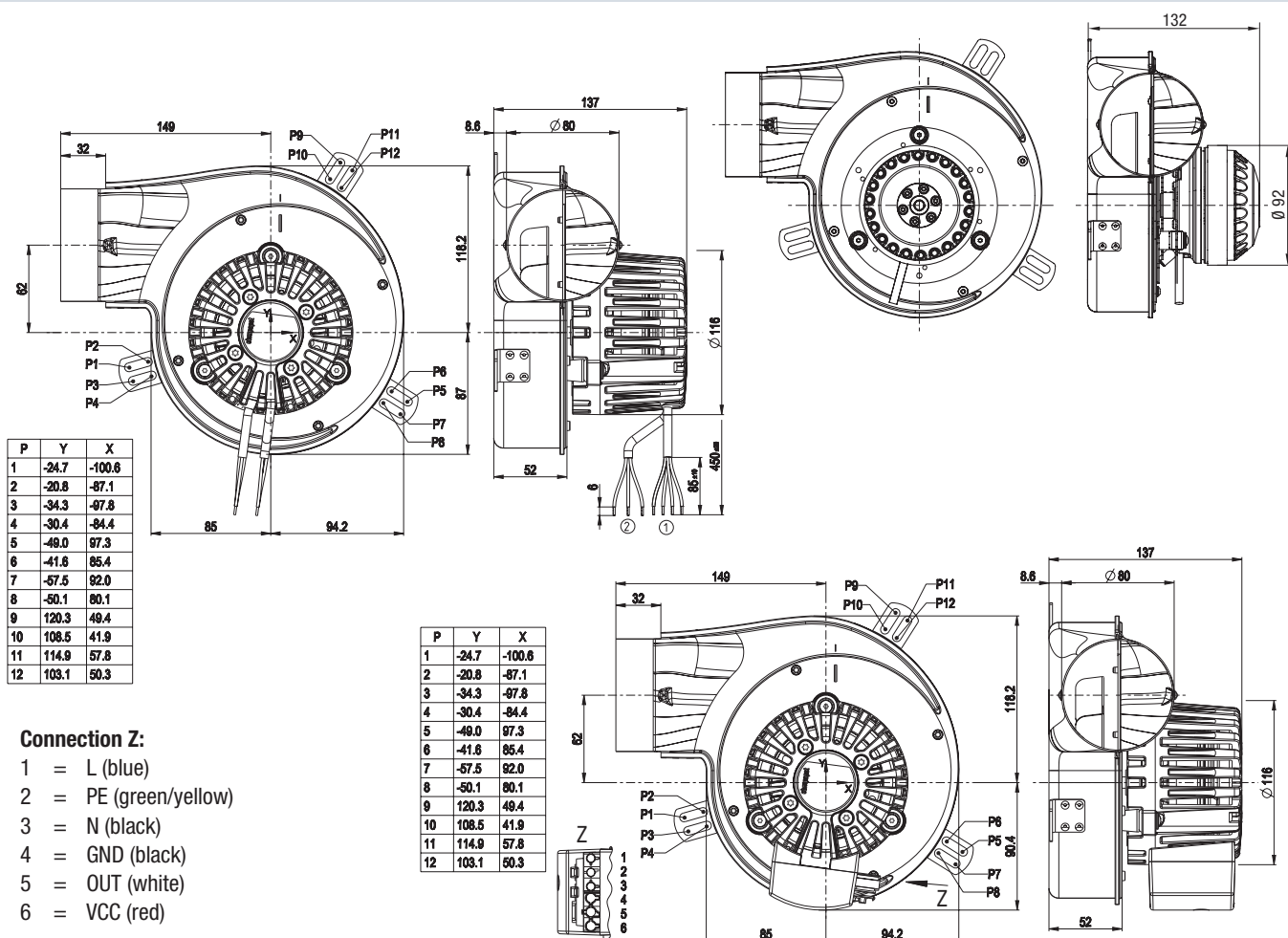

Connection Z:

- 1 = L (blue)
- 2 = PE (green/yellow)
- 3 = N (black)
- 4 = GND (black)
- 5 = OUT (white)
- 6 = VCC (red)

AC centrifugal blowers (exhaust air)

for solid fuel heating systems, single inlet, Ø 152



- **Material:** Impeller: Corrosion resistant sheet steel
Housing: Hot-dip aluminised sheet steel
- **Direction of rotation:** Clockwise, seen on impeller
- **Type of protection:** IP 00
- **Insulation class:** "H"
- **Mounting position:** Any, except motor overhead
- **Mode of operation:** Continuous operation (S1)
- **Bearings:** Ball bearings / sleeve bearings
- **Max. exhaust gas temperature:** Continuous operation 250°C

Nominal data

Type	Curve	Nominal voltage	Frequency	Air flow	Speed/rpm	Max. input power	Max. current draw	Sound pressure level	Perm. amb. temp.	Mass	Electr. connection
	VAC	Hz	m ³ /h	rpm	W	A	dB(A)	°C	kg		
G2E 152 / 0020-3030	Ⓐ	230	50	160	2600	43	0,38	---	-25..+70	2,3	B)

subject to alterations

Curves:

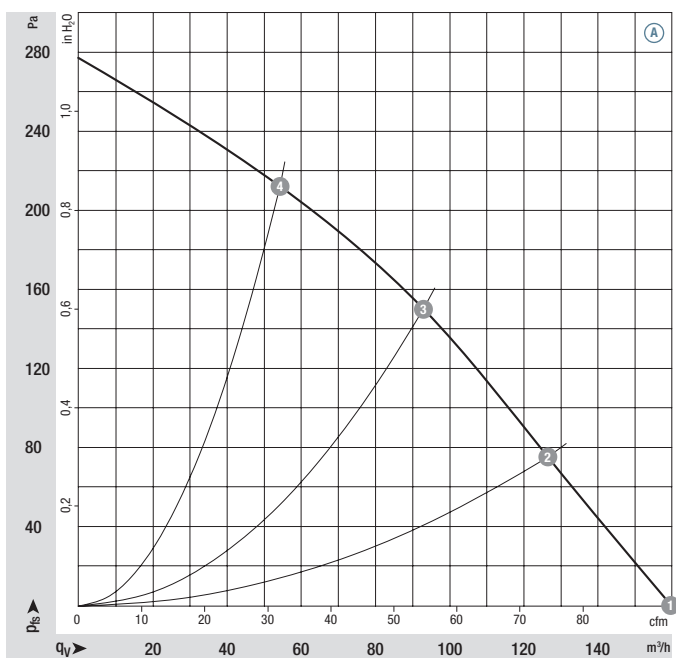

	n rpm	P _{ed} W	I A	L _{pA} dB(A)
Ⓐ 1	2600	43	0,38	---
Ⓐ 2	2630	43	0,37	---
Ⓐ 3	2660	42	0,37	---
Ⓐ 4	2700	39	0,35	---

Air performance measured as per: ISO 5801, Installation category A, with ebm-papst scroll housing without protection against accidental contact. Suction-side noise levels: L_{WA} as per ISO 13347, L_{pA} measured at 1 m distance to fan axis. The acoustic values given are only valid under the measurement conditions listed and may vary depending on the installation situation. With any deviation to the standard setup, the specific values have to be checked and reviewed once installed or fitted! For detailed information see page 100 ff.

- **Motor protection:** TOP wired internally
- **Standard:** Speed monitoring via Hall IC
- **Protection class:** I
- **Product conforming to standards:** EN 60335-1, CE
- **Approvals:** CCC, GOST are applied for; UL, CSA on request
- **Optional:** Additional shaft seal made from ceramic (see p. 94)

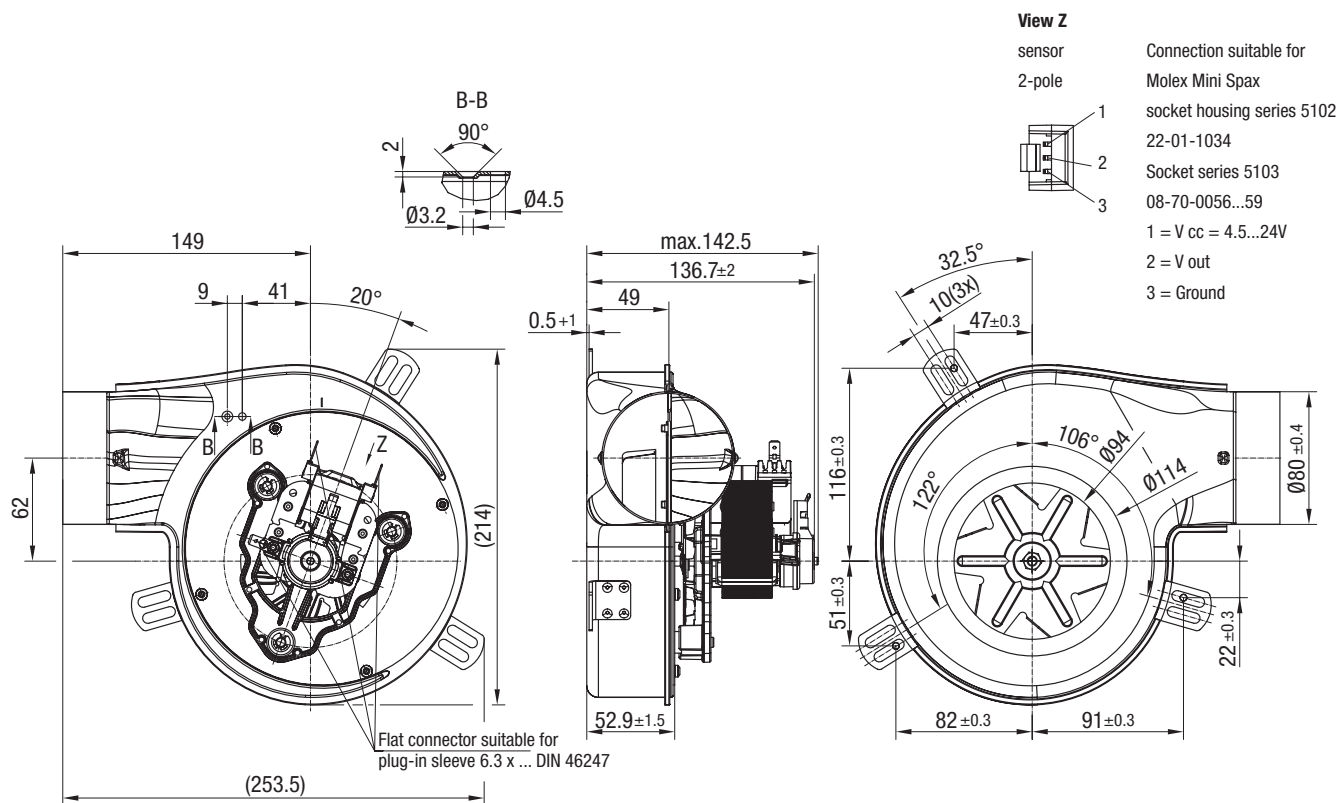

AC centrifugal blowers (exhaust air)

for solid fuel heating systems, single inlet, Ø 180



- **Material:** Impeller: Corrosion resistant sheet steel
Housing: Hot-dip aluminised sheet steel
- **Direction of rotation:** Clockwise, seen on impeller
- **Type of protection:** IP 44
- **Insulation class:** "F"
- **Mounting position:** Any
- **Condensate discharges:** None, open rotor
- **Mode of operation:** Continuous operation (S1)
- **Bearings:** Maintenance-free ball bearings
- **Max. exhaust gas temperature:** Continuous operation 250°C

Nominal data

Type	Motor	Curve	Nominal voltage	Frequency	Air flow	Speed/rpm	Max. input power	Max. current draw	Capacitor	Sound pressure level	Perm. amb. temp.	Mass	Electr. connection
		VAC	Hz	m ³ /h	rpm	W	A	µF/VDB	dB(A)	°C	kg		
G2E 180-CV82 -**	M2E 068-CF	A	230	50	340	2600	65	0,30	1,0/400	73	-25..+60	3,0	p. 98, 99
G2E 180-GV82 -**													A1), D)

subject to alterations

Curves:

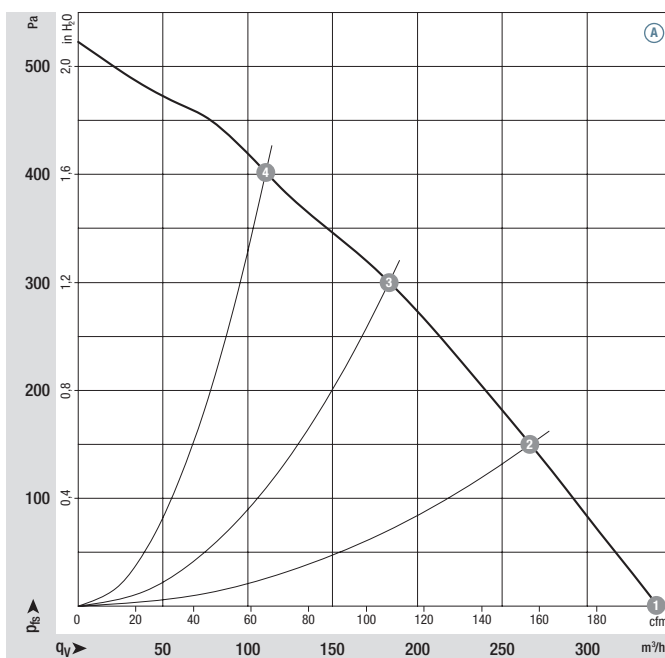

	n rpm	P _{ed} W	I A	L _{pA} dB(A)
A 1	2600	65	0,30	73
A 2	2645	60	0,26	70
A 3	2700	55	0,24	64
A 4	2765	48	0,21	62

Air performance measured as per: ISO 5801, Installation category A, with ebm-papst scroll housing without protection against accidental contact. Suction-side noise levels: L_{WA} as per ISO 13347, L_{pA} measured at 1 m distance to fan axis. The acoustic values given are only valid under the measurement conditions listed and may vary depending on the installation situation. With any deviation to the standard setup, the specific values have to be checked and reviewed once installed or fitted! For detailed information see page 100 ff.

- **Motor protection:** TOP wired internally
- **Touch current:** < 0,75 mA acc. to IEC 60990 (test circuit, illustration 4)
- **Standard:** Speed monitoring via Hall IC
- **Protection class:** I
- **Product conforming to standards:** EN 60335-1, CE
- **Approvals:** UL, CSA, CCC, GOST are applied for
- **Optional:** Additional shaft seal made from ceramic (see p. 94)

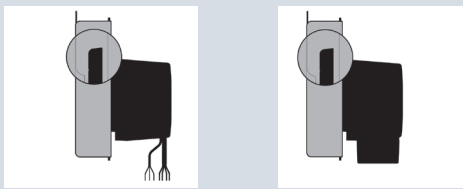
Selection			Dimensions
Type	Cable design *	Plug design	a
G2E 180-CV82 -**	G2E 180-CV82 -01	G2E 180-CV82 -05	186
G2E 180-GV82 -**	G2E 180-GV82 -01	G2E 180-GV82 -05	223

* Cable design also possible without protection hood

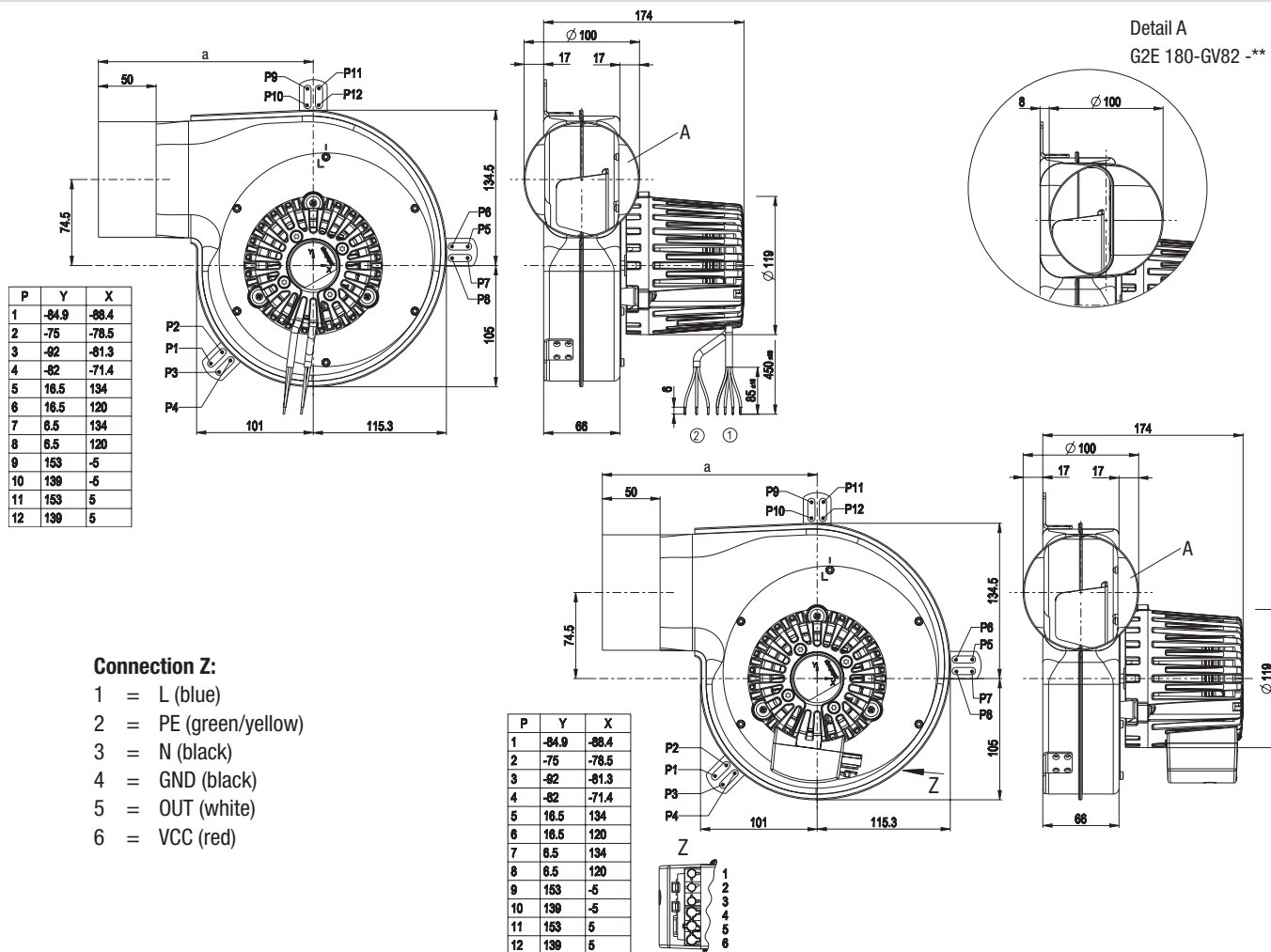



Gear motors

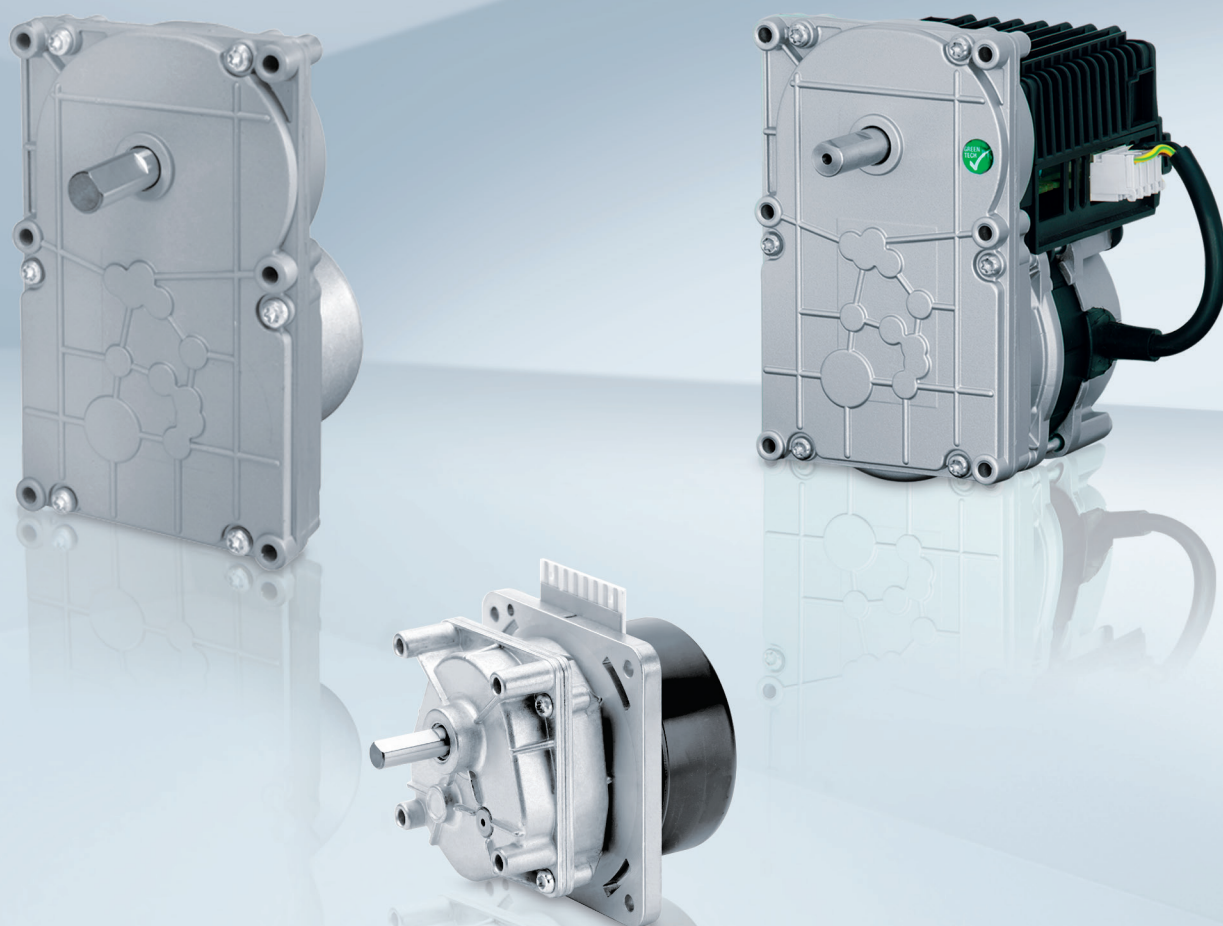

Shaded-pole motor EM 30

with Flatline 78

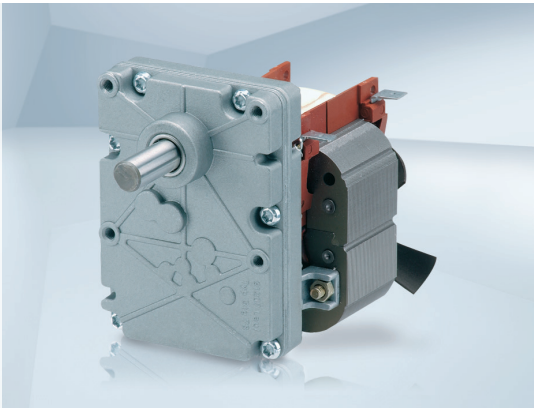

- **Spur gear unit:** Die-cast zinc housing
- **Max. permitted radial load:** 300 N
- **Max. permitted axial load:** 50 N
- **Expected service life:** 5000 h (Lifetime lubrication)
- **Input stage:** Noise optimized
- **Gearbox output shaft:** Needle bearings
- **Mode of operation:** Continuous operation S1 till to 50 °C ambient air temperature

Nominal data		Nominal voltage	Frequency	Reduction	Drive torque	Output speed	Output power	Nominal current	Mass	Length
Type	Motor	V	Hz	i/No. of stages	M _{ab} (Nm)	n _{ab} (rpm)	P _{ab} (W)	I (A)	m (kg)	L (mm)
78.5.3030.F40	EM3030	230	50	408,4/5	7,4	6,37	4,9	0,46	1,1	87
78.5.3030.F41	EM3030	230	50	737,4/5	12,5	3,53	4,6	0,46	1,1	87
78.5.3020.F42	EM3020	230	50	976,0/5	11,9	2,66	3,3	0,15	0,9	77
78.5.3020.F43	EM3020	230	50	1266,1/5	13,0	2,05	2,8	0,15	0,9	77
78.5.3020.F44	EM3020	230	50	1648,6/5	14,0	1,58	2,3	0,15	0,9	77
78.5.3020.F45	EM3020	230	50	2135,9/5	15,0	1,22	1,9	0,15	0,9	77

Subject to alterations

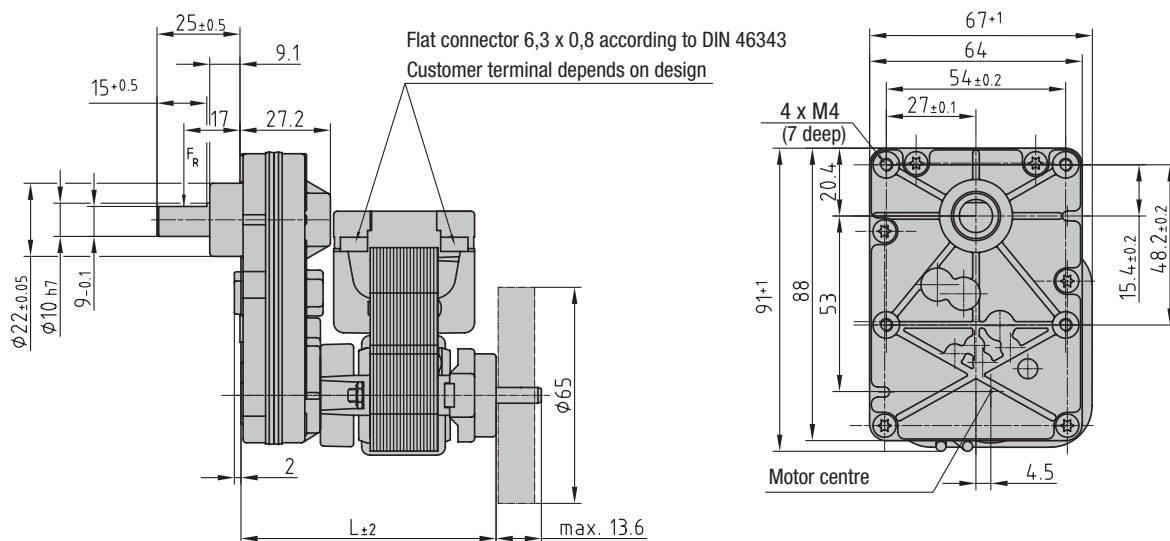

Capacitor motor KM 40

with Compactline 92

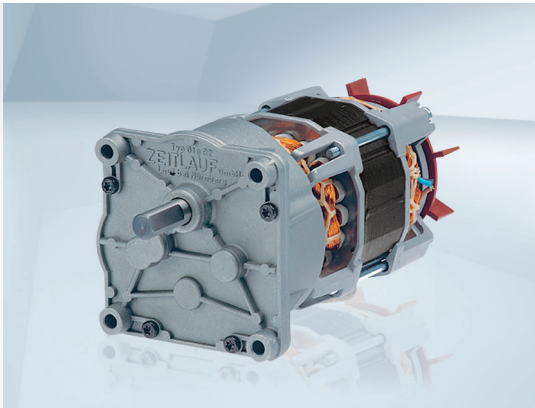

- **Spur gear unit:** Die-cast zinc housing
- **Max. permitted radial load:** 150 N
- **Max. permitted axial load:** 50 N
- **Expected service life:** 5000 h (Lifetime lubrication)
- **Input stage:** Noise optimized
- **Gearbox output shaft:** Slide/needle bearings
- **Mode of operation:** Continuous operation S1 till to 50 °C ambient air temperature

Nominal data		Nominal voltage	Frequency	Reduction	Drive torque	Output speed	Output power	Nominal current	Capacitor	Mass	Length
Type	Motor	V	Hz	i/No. of stages	M _{ab} (Nm)	n _{ab} (rpm)	P _{ab} (W)	I (A)	μF/V	m (kg)	L (mm)
92.3.4050.2.C06	KM4050-2	230	50	55,0/3	10,0	50,0	52	0,68	5,0/400	2,1	153
92.3.4050.2.C07	KM4050-2	230	50	70,4/3	12,8	39,1	52	0,68	5,0/400	2,1	153
92.3.4050.2.C08	KM4050-2	230	50	92,3/3	15,0	29,8	47	0,68	5,0/400	2,1	153
92.3.4030.2.C09	KM4030-2	230	50	142,0/3	14,4	19,4	29	0,38	3,5/400	1,6	133
92.3.4030.2.C10	KM4030-2	230	50	184,4/3	15,0	14,9	23	0,38	3,5/400	1,6	133
92.3.4030.2.C11	KM4030-2	230	50	274,6/3	15,0	10,0	16	0,38	3,5/400	1,6	133
92.3.4030.4.C12	KM4030-4	230	50	142,0/3	12,9	9,15	12	0,20	1,5/400	1,6	133
92.3.4030.4.C13	KM4030-4	230	50	184,4/3	15,0	7,05	11	0,20	1,5/400	1,6	133
92.3.4030.4.C14	KM4030-4	230	50	274,6/3	15,0	4,73	7,4	0,20	1,5/400	1,6	133

Subject to alterations

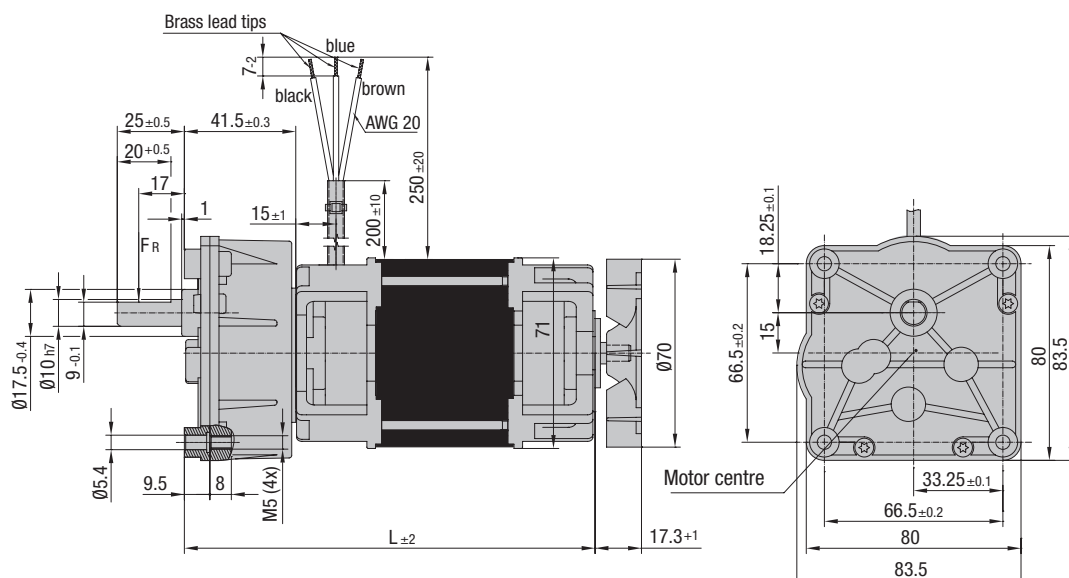

Capacitor motor KM 40

with Flatline 85

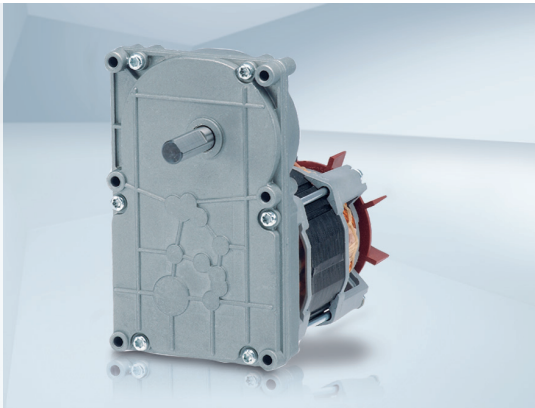

- **Spur gear unit:** Die-cast zinc housing
- **Max. permitted load:** 150 N
- **Max. permitted axial load:** 50 N
- **Expected service life:** 5000 h (Lifetime lubrication)
- **Input stage:** Noise optimized
- **Gearbox output shaft:** Needle bearings on both sides
- **Mode of operation:** Continuous operation S1 till to 50 °C ambient air temperature

Nominal data		Nominal voltage	Frequency	Reduction	Drive torque	Output speed	Output power	Nominal current	Capacitor	Mass	Length
Type	Motor	V	Hz	i/No. of stages	M _{ab} (Nm)	n _{ab} (rpm)	P _{ab} (W)	I (A)	μF/V	m (kg)	L (mm)
85.3.4050.2.F08	EM4050-2	230	50	136,5/3	24,9	20,1	52	0,68	5,0/400	2,1	139
85.3.4050.2.F09	EM4050-2	230	50	189,0/3	25,0	14,6	38	0,68	5,0/400	2,1	139
85.4.4030.F10	KM4030-2	230	50	303,6/4	27,7	9,06	26	0,38	3,5/400	1,7	119
85.4.4030.F11	KM4030-2	230	50	454,0/4	30,0	6,06	19	0,38	3,5/400	1,7	119
85.4.4030.F12	KM4030-2	230	50	687,0/4	30,0	4,00	13	0,38	3,5/400	1,7	119
85.5.4030.F13	KM4030-2	230	50	1028,7/4	30,0	2,67	8,4	0,38	3,5/400	1,7	119

Subject to alterations

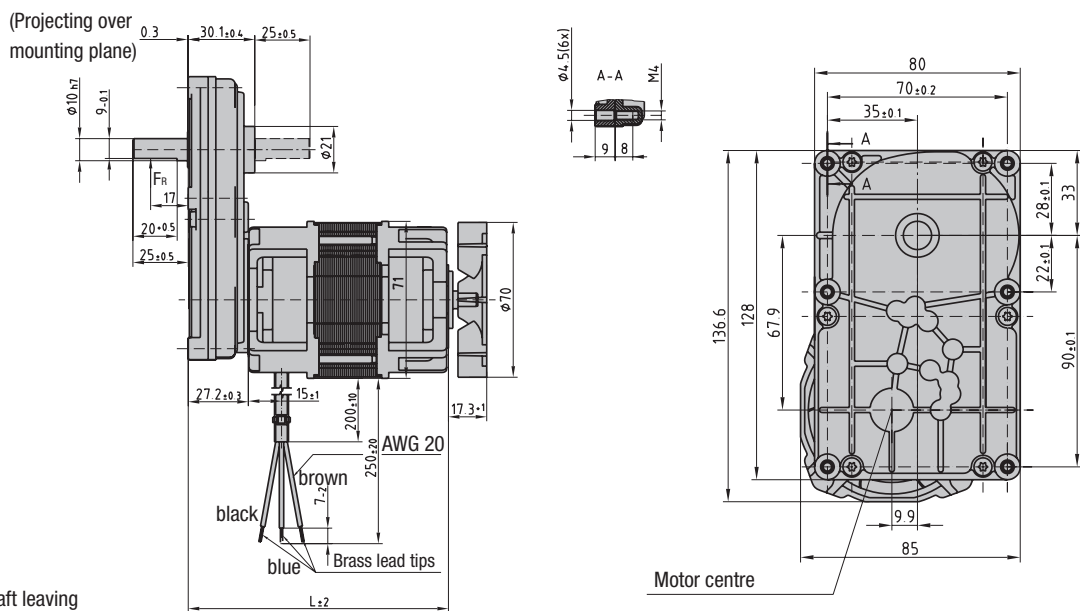

Alternative shaft leaving on motor-side on request order adding: W03

EC motor VDC 3-49-15

with Flatline 85



- **Spur gear unit:** Die-cast zinc housing
- **Max. permitted radial load:** 150 N
- **Max. permitted axial load:** 50 N
- **Expected service life:** 5000 h (Lifetime lubrication)
- **Input stage:** Noise optimized
- **Gearbox output shaft:** Needle bearings on both sides
- **Mode of operation:** Continuous operation S1 till to 50 °C ambient air temperature

Nominal data		Nominal voltage	Reduction	Drive torque	Output speed	Output power	Nominal current	Mass	Length
Type	Motor	V	i/No. of stages	M _{ab} (Nm)	n _{ab} (rpm)	P _{ab} (W)	I (A)	m (kg)	L (mm)
85.3.C4915.F01	VDC-3-49-15	24	8,2/3	0,9	488	46	3,5	1,4	88
85.3.C4915.F02	VDC-3-49-15	24	12,3/3	1,3	325	46	3,5	1,4	88
85.3.C4915.F03	VDC-3-49-15	24	27,6/3	3,0	145	46	3,5	1,4	88
85.3.C4915.F04	VDC-3-49-15	24	40,3/3	4,4	99,3	46	3,5	1,4	88
85.3.C4915.F05	VDC-3-49-15	24	64,0/3	7,0	62,5	46	3,5	1,4	88
85.3.C4915.F06	VDC-3-49-15	24	101,8/3	11,0	39,3	46	3,5	1,4	88
85.3.C4915.F07	VDC-3-49-15	24	136,5/3	15,0	29,3	46	3,5	1,4	88
85.3.C4915.F08	VDC-3-49-15	24	189,0/3	21,0	21,2	46	3,5	1,4	88

Subject to alterations

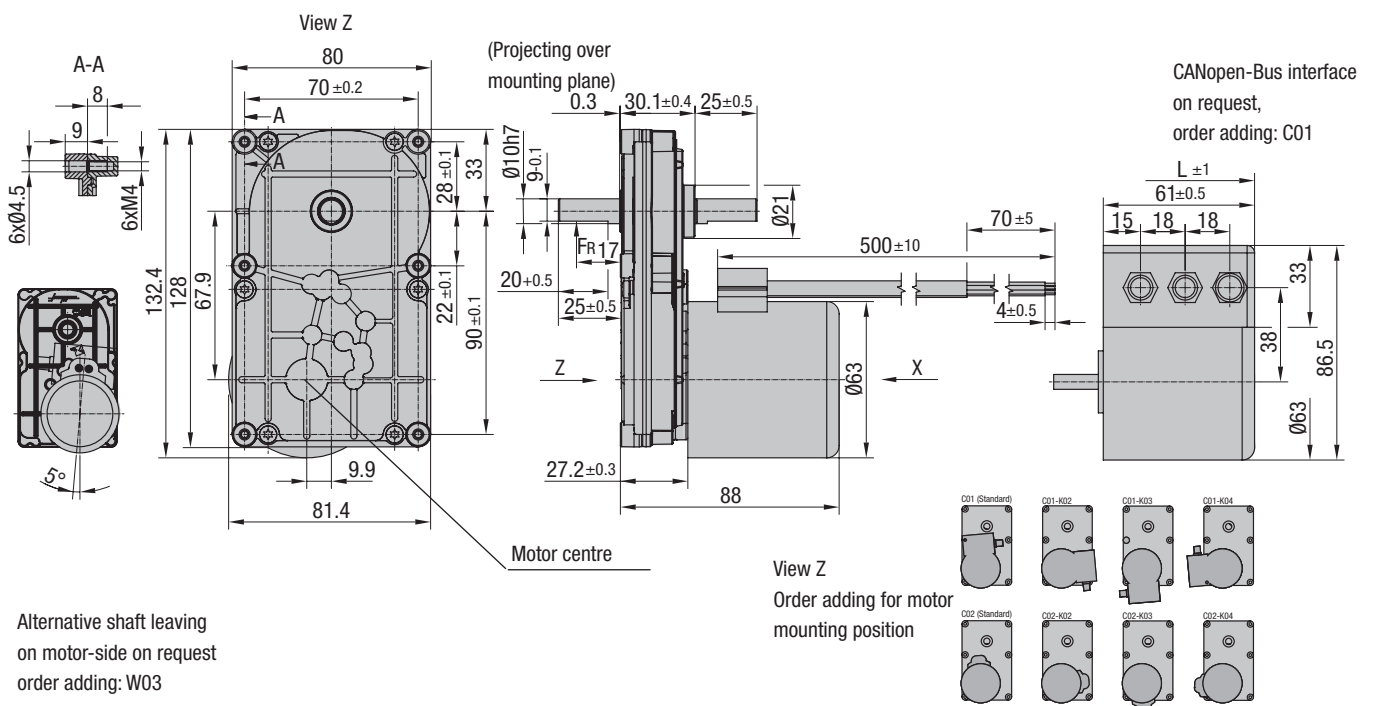

EC motor VDC 3-54-14

with Flatline 85



- **Spur gear unit:** Die-cast zinc housing
- **Max. permitted radial load:** 150 N
- **Max. permitted axial load:** 50 N
- **Expected service life:** 5000 h (Lifetime lubrication)
- **Input stage:** Noise optimized
- **Gearbox output shaft:** Needle bearings on both sides
- **Mode of operation:** Continuous operation S1 till to 50 °C ambient air temperature

Nominal data		Nominal voltage	Reduction	Drive torque	Output speed	Output power	Nominal current	Mass	Length
Type	Motor	V	i/No. of stages	M _{ab} (Nm)	n _{ab} (rpm)	P _{ab} (W)	I (A)	m (kg)	L (mm)
85.4.C5414.F11	VDC-3-54-14	24	454,0/4	30,0	7,71	24	2,8	1,1	70
85.4.C5414.F13	VDC-3-54-14	24	1028,7/4	30,0	3,40	11	2,8	1,1	70

Subject to alterations

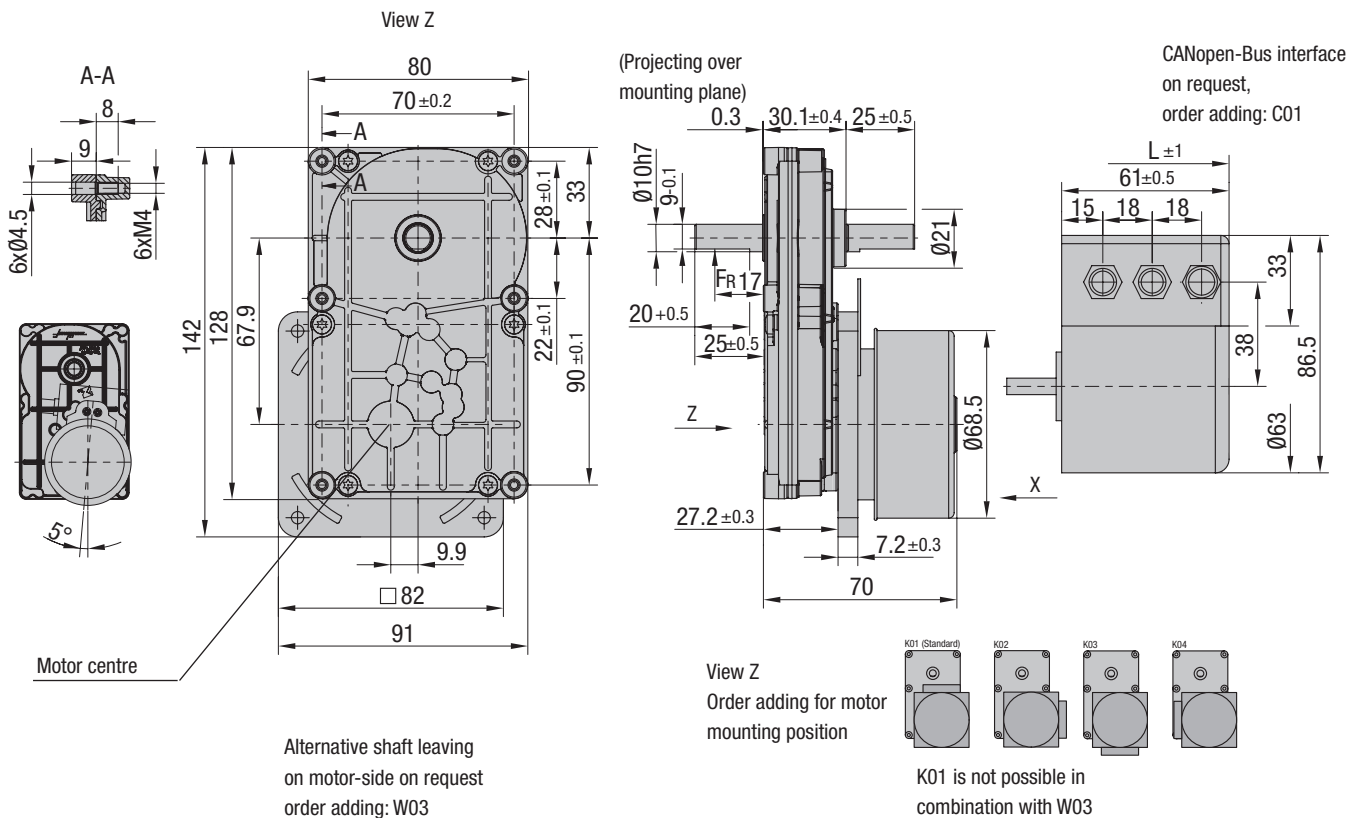

EC motor VDC 3-54-14

with Compactline 90

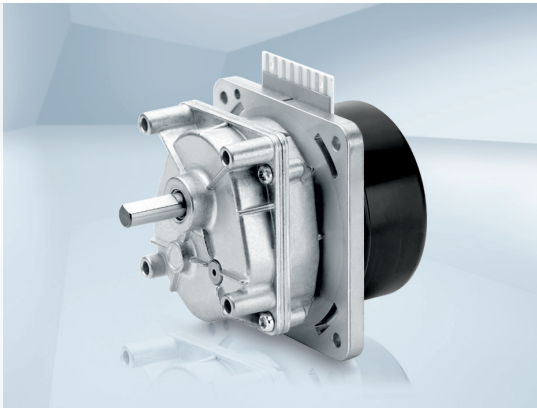

- **Spur gear unit:** Die-cast zinc housing
- **Max. permitted radial load:** 120 N
- **Max. permitted axial load:** 40 N
- **Expected service life:** 5000 h (Lifetime lubrication)
- **Input stage:** Noise optimized
- **Gearbox output shaft:** Slide/needle bearings
- **Mode of operation:** Continuous operation S1 till to 50 °C ambient air temperature

Nominal data		Nominal voltage	Reduction	Drive torque	Output speed	Output power	Nominal current	Mass	Length
Type	Motor	V	i/No. of stages	M _{ab} (Nm)	n _{ab} (rpm)	P _{ab} (W)	I (A)	m (kg)	L (mm)
90.2.C5414.C01	VDC-3-54-14	24	16,0/2	1,7	219	39	2,8	0,8	84
90.2.C5414.C05	VDC-3-54-14	24	32,0/2	3,4	109	39	2,8	0,8	84
90.3.C5414.C07	VDC-3-54-14	24	57,8/3	5,5	60,6	35	2,8	0,8	84
90.3.C5414.C08	VDC-3-54-14	24	79,1/3	7,0	44,2	32	2,8	0,8	84
90.3.C5414.C09	VDC-3-54-14	24	121,6/3	7,0	28,8	21	2,8	0,8	84
90.4.C5414.C10	VDC-3-54-14	24	189,0/4	9,0	18,5	17	2,8	0,9	84
90.4.C5414.C12	VDC-3-54-14	24	368,0/4	9,0	9,51	9	2,8	0,9	84

Subject to alterations

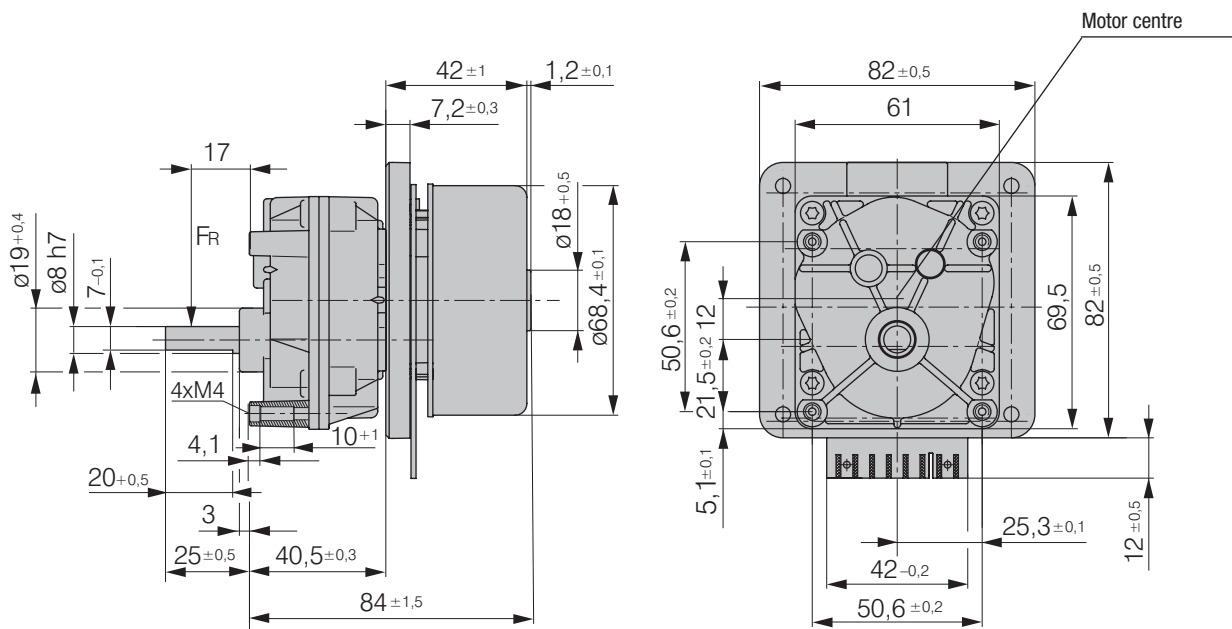

EC motor BG 4310

with Compactline 92



- **Spur gear unit:** Die-cast zinc housing
- **Type of protection:** IP 20
- **Max. permitted radial load:** 150 N
- **Max. permitted axial load:** 50 N
- **Expected service life:** 5000 h (Lifetime lubrication)
- **Input stage:** Noise optimized
- **Gearbox output shaft:** Needle bearings on both sides
- **Mode of operation:** Continuous operation S1 till to 50 °C ambient air temperature
- **Technical features:**
 - Control input 0-10 V (optional PWM)
 - cw (optional reverse on start)
 - Tach output optional

Nominal data		Nominal voltage	Frequency	Reduction	Drive torque	Output speed	Output power	Nominal current	Mass	Length
Type	Motor	V	Hz	i/No. of stages	M _{ab} (Nm)	n _{ab} (rpm)	P _{ab} (W)	I (A)	m (kg)	L (mm)
92.3.B4310.C01	BG 4310	230	50	184,4/3	15	2,71...16,27	25	---	1,4	100
92.3.B4310.C02	BG 4310	230	50	274,6/3	20	1,82...10,92	23	---	1,4	100

Subject to alterations

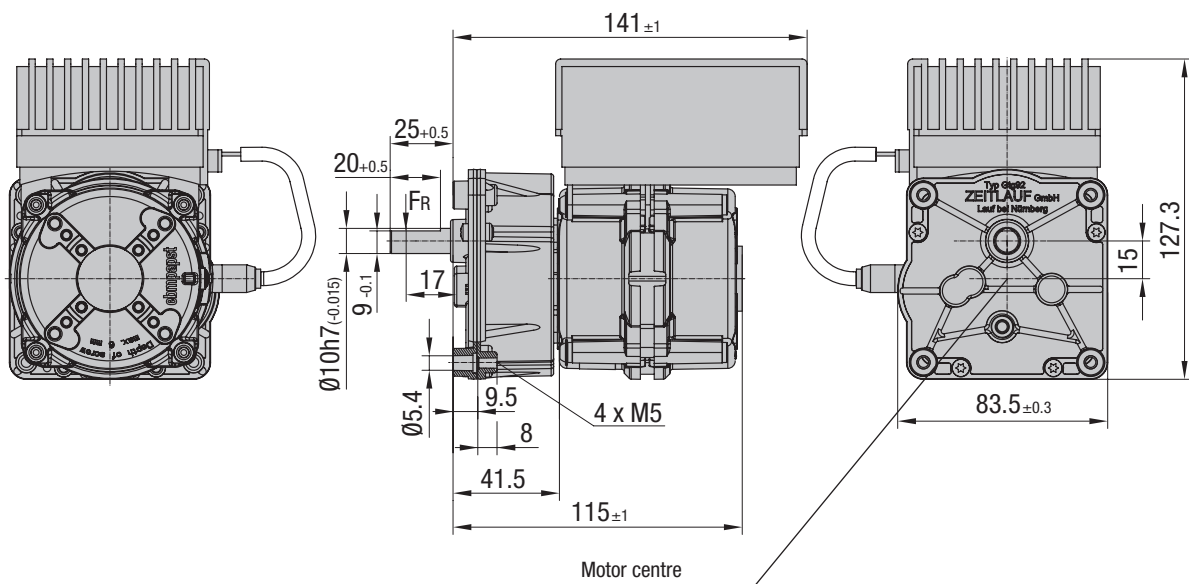

EC motor BG 4310

with Flatline 85



- **Spur gear unit:** Die-cast zinc housing
- **Type of protection:** IP 20
- **Max. permitted radial load:** 150 N
- **Max. permitted axial load:** 50 N
- **Expected service life:** 5000 h (Lifetime lubrication)
- **Input stage:** Noise optimized
- **Gearbox output shaft:** Needle bearings on both sides
- **Mode of operation:** Continuous operation S1 till to 50 °C ambient air temperature
- **Technical features:**
Control input 0-10 V (optional PWM)
cw (optional reverse on start)
Tach output optional

Nominal data		Nominal voltage	Frequency	Reduction	Drive torque	Output speed	Output power	Nominal current	Mass	Length
Type	Motor	V	Hz	i/No. of stages	M _{ab} (Nm)	n _{ab} (rpm)	P _{ab} (W)	I (A)	m (kg)	L (mm)
85.4.B4310.F01	BG 4310	230	50	303,6/4	25	1,65...9,88	26	---	1,5	106
85.4.B4310.F02	BG 4310	230	50	454,0/4	30	1,10...6,61	21	---	1,5	106

Subject to alterations

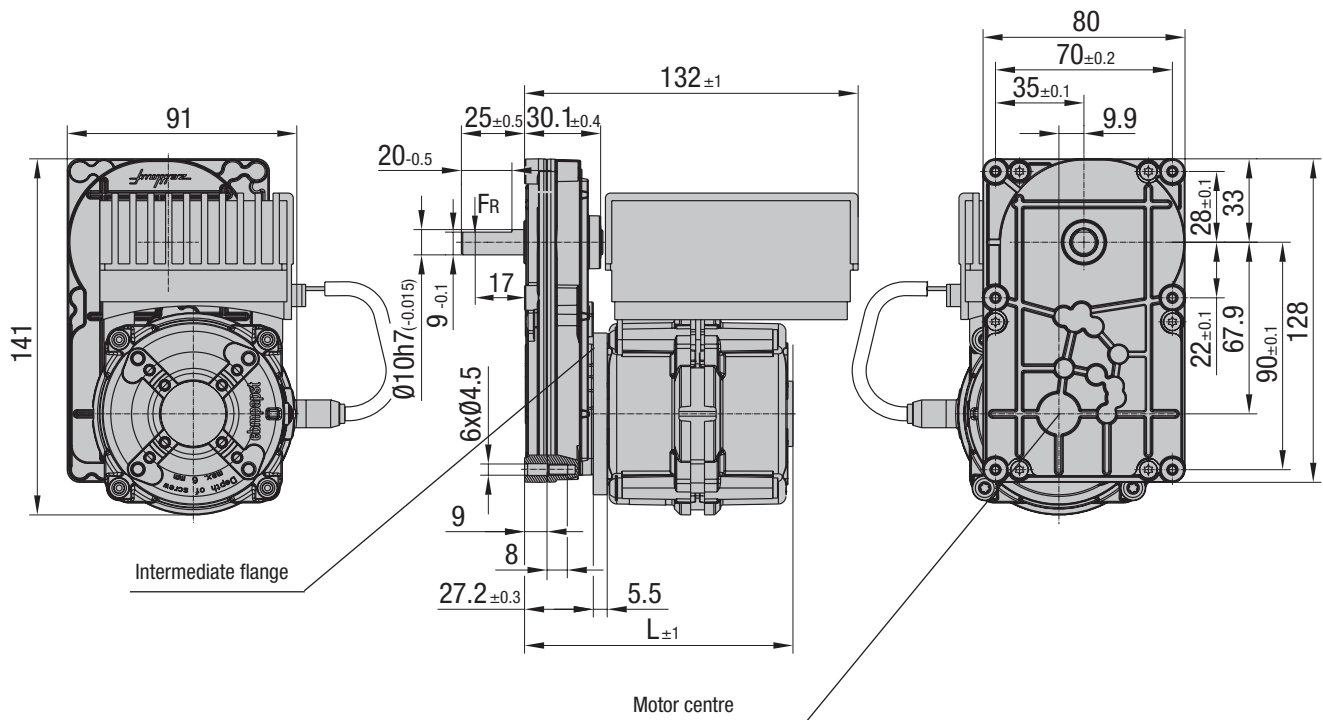

Scroll dimensions

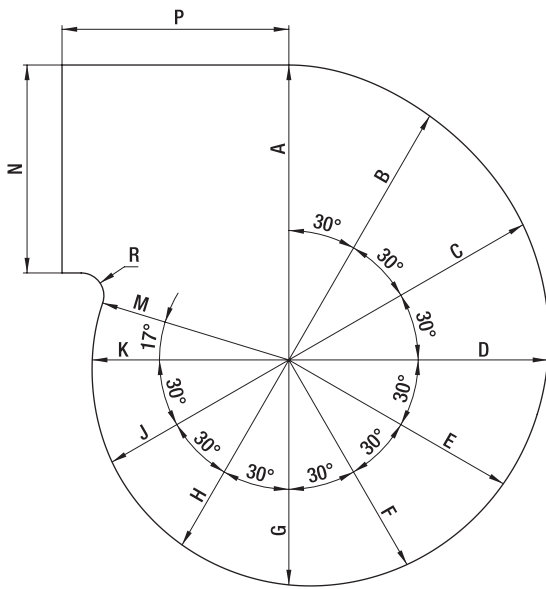

Scroll dimensions for AC / EC centrifugal fans (recommended by ebm-papst)

Size	A	B	C	D	E	F	G	H	J	K	M	N	P	R
Ø 140	121	116	111	106	102	97	92	88	84	82	80	86	93	9
Ø 150/152	130	124	119	114	109	104	99	94	90	87	86	92	100	10
Ø 160	139	132	127	122	116	111	106	100	96	93	92	98	107	11
Ø 180	156	149	143	137	131	125	119	113	108	104	103	110	120	12
Ø 210	182	174	167	160	152	146	139	132	127	121	120	128	140	14
Ø 250	218	209	200	192	182	175	167	158	152	145	144	154	168	19

subject to alterations

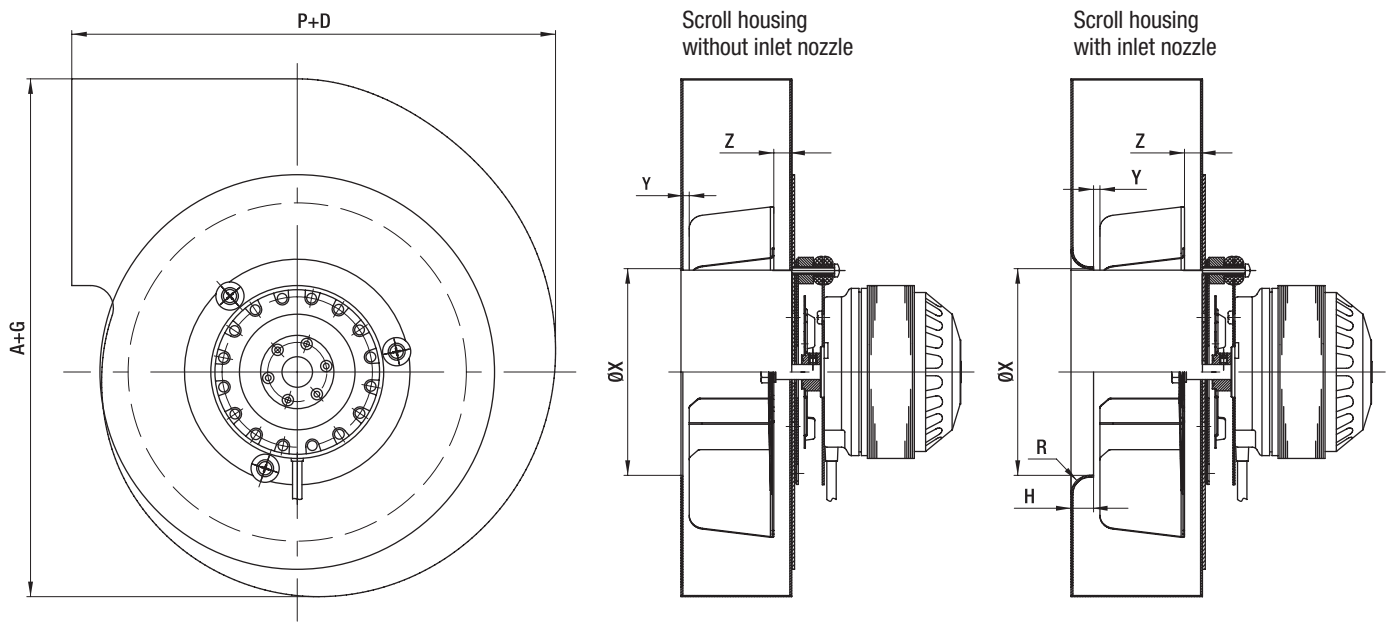

Distance between impeller and scroll housing/inlet nozzle (recommended by ebm-papst)

Size	X	Y	Z	R	H
Ø 140	80-100	3-5	8-11	10	10
Ø 150/152	90-110	3-5	8-11	10	10
Ø 160	100-120	3-5	8-11	10	10
Ø 180	110-130	3-5	8-11	12	12
Ø 210	120-135	3-5	8-11	12	12
Ø 250	140-160	3-5	8-11	12	12

subject to alterations

Additional shaft seal

ebm-papst also offers an additional shaft seal for its exhaust gas blowers. This was developed specifically for this application, intended for installation in passive and low-energy houses with regulated ventilation in apartments, for example.

The sealing system is made from high temperature-resistance ceramic and ensures low leakage over the long term.

The final suitability of the system must be qualified and approved in the end device.

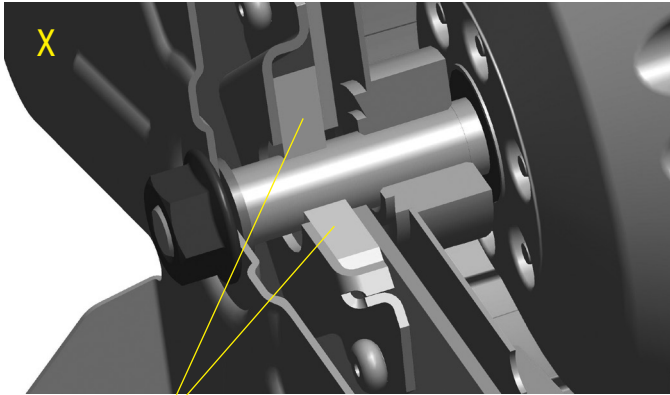
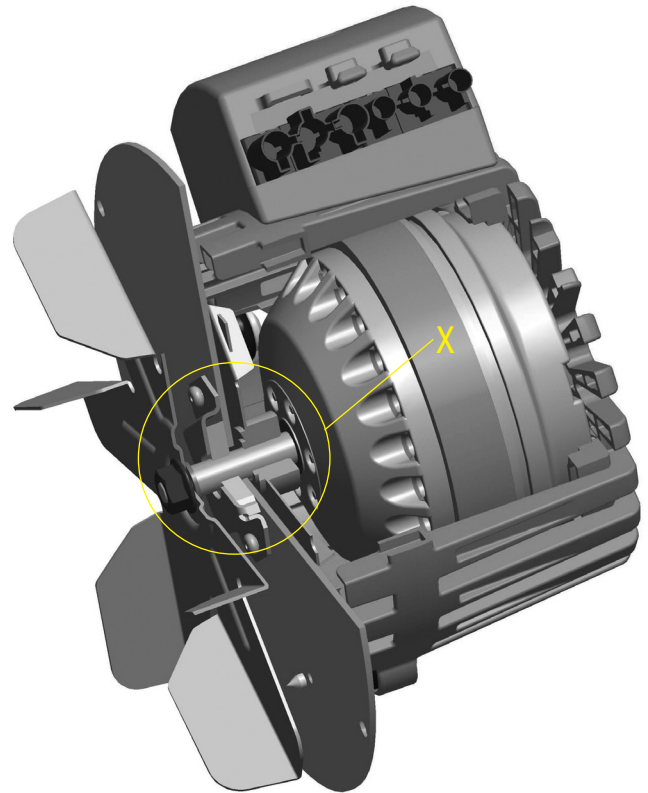

Shaft seal made from ceramic

Electrical connection EC (11) Tangential blowers

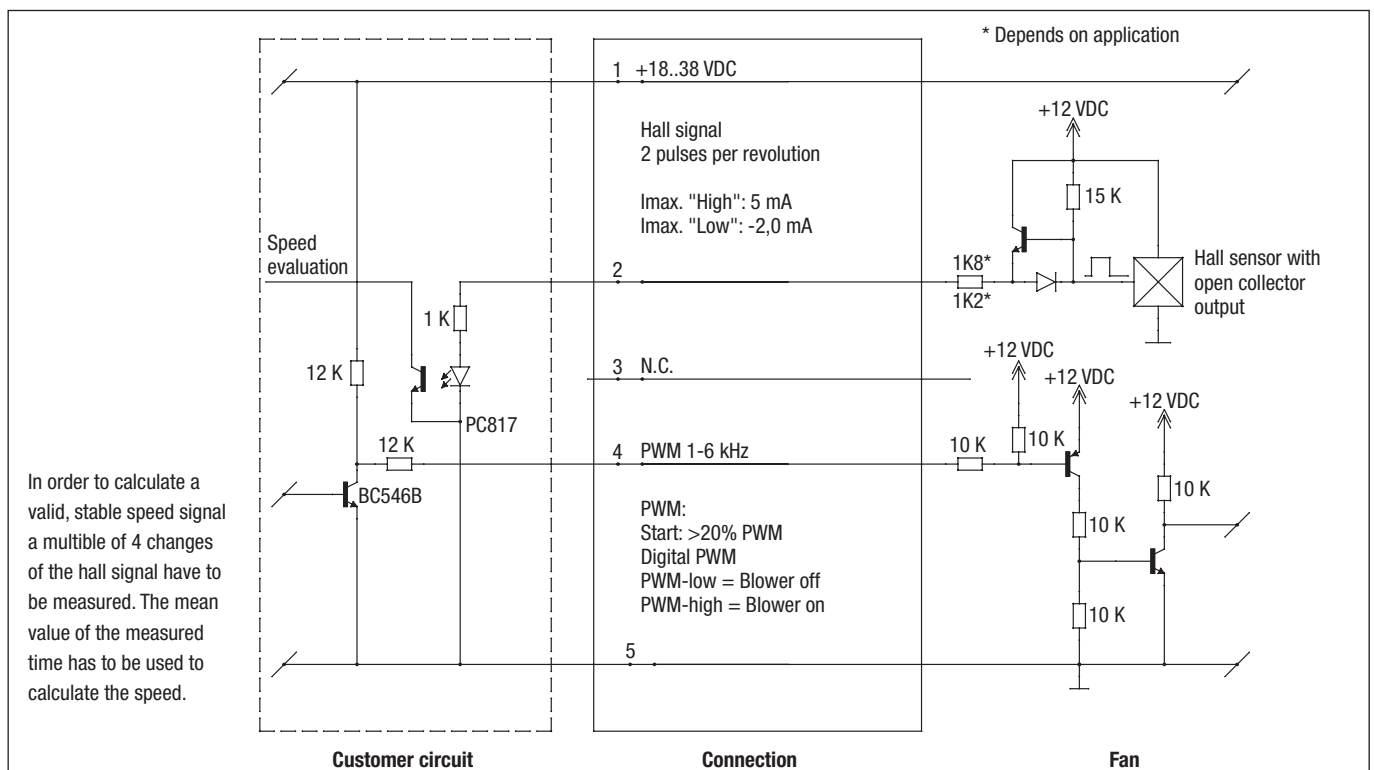

Electrical connections EC H1)

Technical features:

- PFC (passive)
- Output 10 VDC max. 1,1 mA
- Tach output
- Control input 0-10 VDC / PWM
- Over-temperature protected electronics / motor

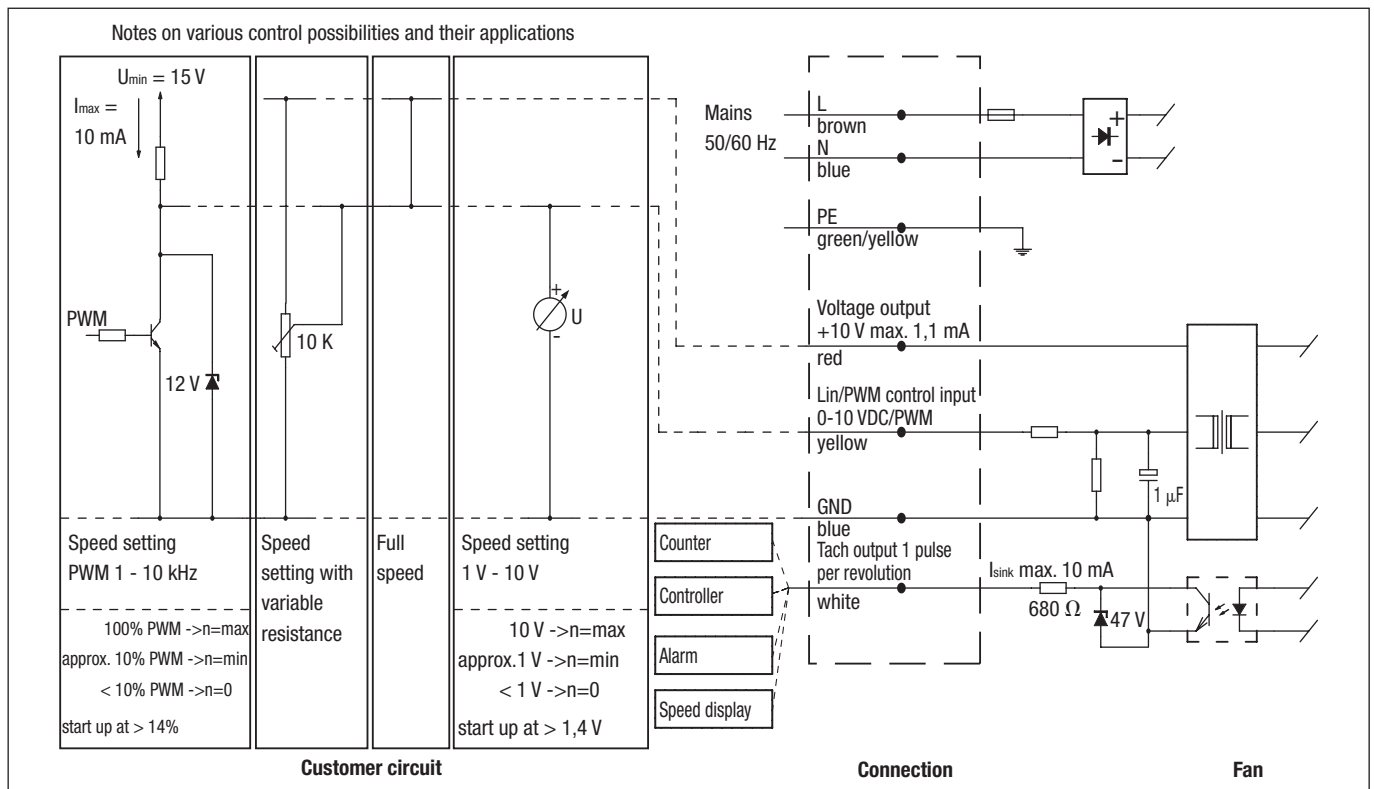

Electrical connections EC H4)

Technical features:

- Control input 0-10 VDC / PWM
- Output 10 VDC max. 1,1 mA
- Tach output
- Line undervoltage detection
- Locked-rotor protection
- Soft start
- Over-temperature protected electronics / motor

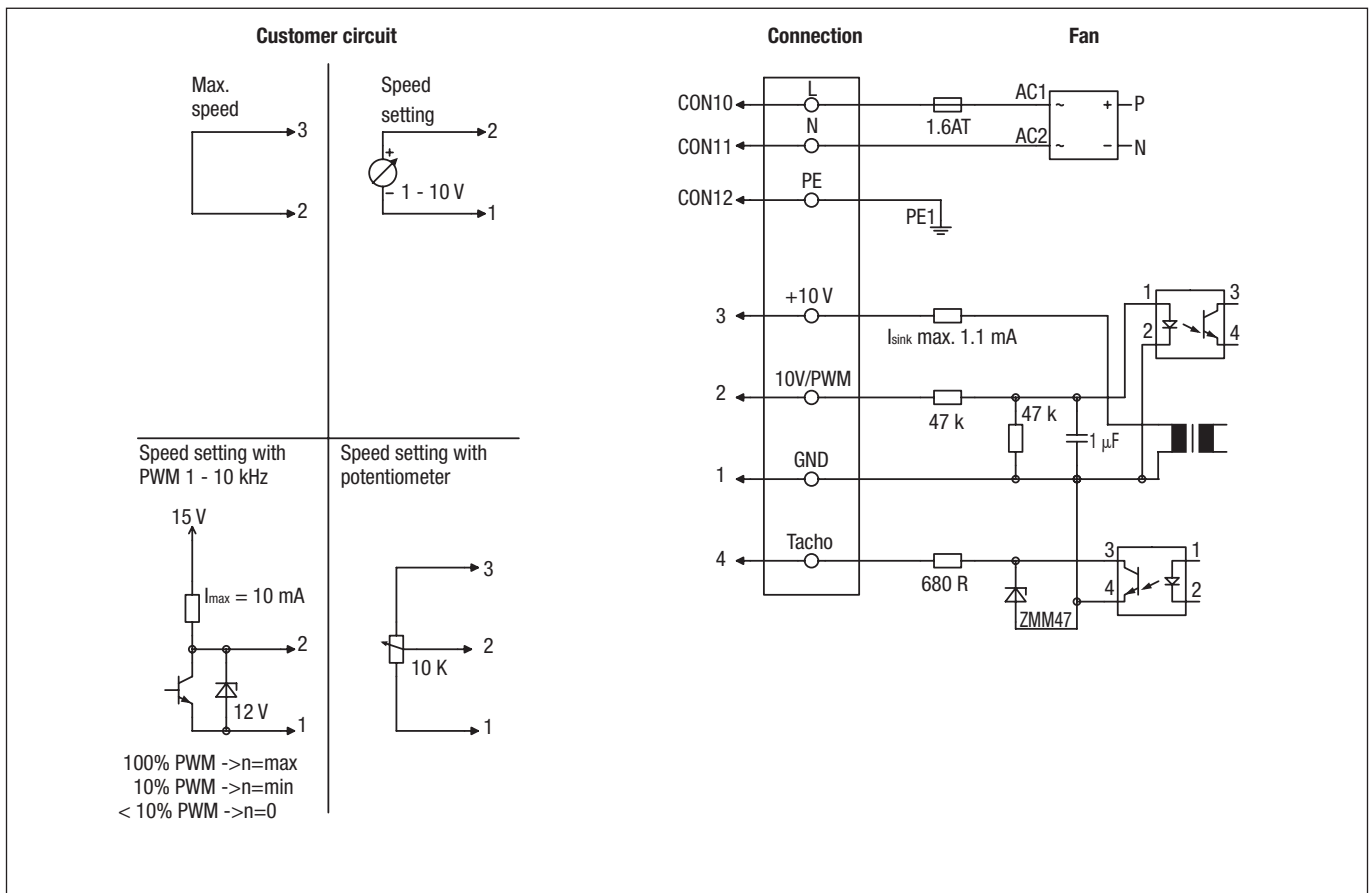

Line	Connection	Colour	Assignment / function
CON10	L	black	Power supply 230 VAC, 50 - 60 Hz, see type plate for voltage range
CON11	N	blue	Neutral conductor
CON12	PE	green/yellow	Protective earth
1	GND	blue	GND-Connection for control interface
2	0-10V / PWM	yellow	Control input 0-10V or PWM, electrically isolated
3	10V max. 1.1 mA	red	Voltage output 10V / 1.1 mA, electrically isolated, not short-circuit-proof
4	Tacho	white	Tach output: Open Collector, 1 pulse per revolution, electrically isolated

Electrical connections EC J5)

Technical features:

- Control input 0-10 VDC / PWM
- Tach output
- Motor current limitation
- Reverse polarity and locked-rotor protection
- Soft start

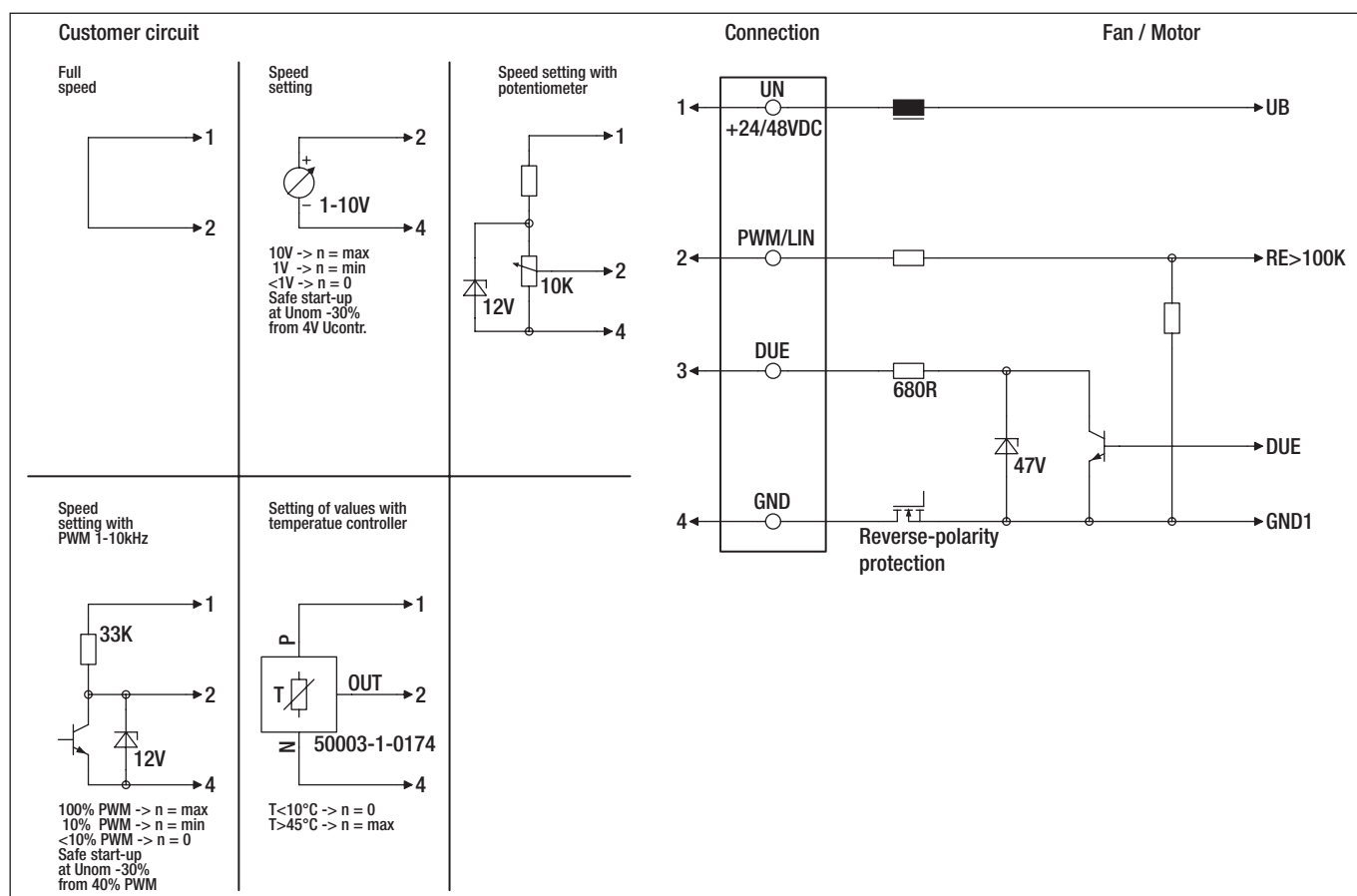

Line	Connection	Colour	Assignment / function
1	UN +24/48 VDC	red	Power supply 24/48 VDC, maximum ripple $\pm 3,5 \%$
2	PWM/LIN	yellow	Control input $R_e > 100 \text{ K}$
3	Tach	white	Tach output, 3 pulses per revolution, $I_{\text{sink max.}} = 10 \text{ mA}$
4	GND	blue	Reference ground

Electrical connections AC

A1) / B)

A1) Single-phase capacitor motor
with TOP wired internally

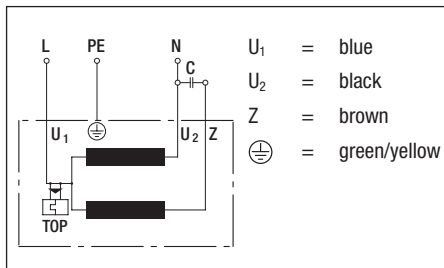

B) Shaded pole motor
with TOP wired internally

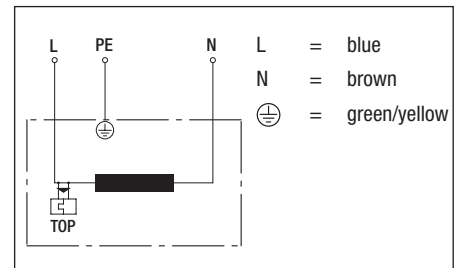

Electrical connections Hall IC C) / D)

C) Speed monitoring with EC fans

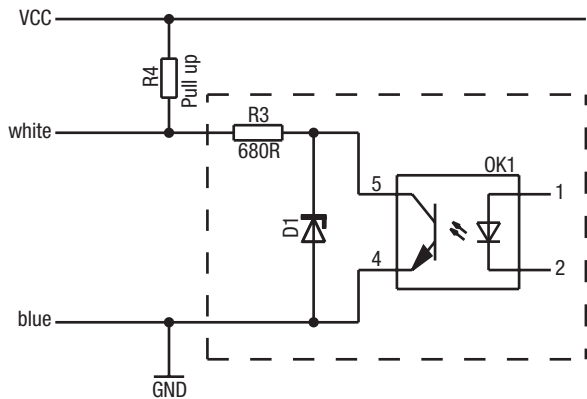

Fan connections: white (OUT): Speed signal
 blue (IN): Ground connection

Specification from ebm-papst:
 $I_{sink_{max}} = 10 \text{ mA}$ (by transistor in OK1)
 $V_{CC_{max}} = 40 \text{ V}$ (external supply to be provided by customer)
 Pull up resistor = Pay attention to power loss of the resistors in dimensioning!

D) Speed monitoring with AC fans

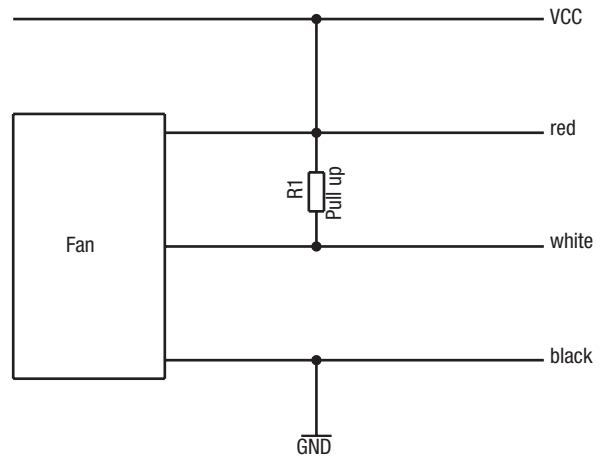

Fan connections: red (IN): DC-Voltage
 white (OUT): Speed signal
 black (IN): Ground connection

Specification from ebm-papst:
 $V_{CC} = 5 \text{ VDC}$ (external supply to be provided by customer)
 Pull up resistor = 4,5 k Ω

Technical parameters & scope

High standards for all ebm-papst products

Here at ebm-papst, we constantly strive to further improve our products in order to be able to offer you the best possible product for your application. Careful monitoring of the market ensures that technical innovations are reflected in the improvements of our products. Based on the technical parameters listed below and the ambience you want our product to operate in, we here at ebm-papst can always work out the best solution for your specific application.

General performance parameters

Any deviations from the technical data and parameters described here are listed on the product-specific data sheet.

Type of protection

The type of protection is specified in the product-specific data sheets.

Insulation class

The insulation class is specified in the product-specific data sheets.

Mounting position

The mounting position is specified in the product-specific data sheets.

Condensate discharge holes

Information on the condensate discharge holes is provided in the product-specific data sheets.

Mode of operation

The mode of operation is specified in the product-specific data sheets.

Protection class

The protection class is specified in the product-specific data sheets.



Information on ErP directive for hot air blowers

With implementation of the ErP directive, more stringent efficiency requirements apply in two stages as of 2013 and 2015 for fans in the power range between 125 W and 500 kW. The corresponding minimum efficiency values for the different types of fan are stipulated by the EU.

ebm-papst GreenTech EC fans already surpass the minimum values required by law. Users can recognise fans complying with the directive from the CE marking for example. Exceptions not subject to the directive include fans for conveying hot media at temperatures in excess of 100°C

Service life

The service life of ebm-papst products depends on two major factors:

- The service life of the insulation system
- The service life of the bearing system

The service life of the insulation system mainly depends on voltage level, temperature and ambient conditions, such as humidity and condensation. The service life of the bearing system depends mainly on the thermal load on the bearing.

The majority of our products use maintenance-free ball bearings for any mounting position possible.

The service life L10 of the ball bearings can be taken as approx. 40,000 operating hours at an ambient temperature of 40 °C, yet this estimate can vary according to the actual ambient conditions.

We will gladly provide you with a lifetime calculation taking into account your specific operating conditions.

Motor protection / thermal protection

Information on motor protection and thermal protection is provided in the product-specific data sheets.

Depending on motor type and field of application, the following protective features are realised:

- Thermal overload protection (TOP), either in-circuit or external
- PTC with electronic diagnostics
- Impedance protection
- Thermal overload protection (TOP) with electronic diagnostics
- Current limitation via electronics

If an external TOP is connected, the customer has to make sure to connect a conventional trigger device for switching it off.

Products without fitted TOP and without protection against improper use, a motor protection complying with the valid standards has to be installed.

Mechanical strain / performance parameters

All ebm-papst products are subjected to comprehensive tests complying with the normative specifications. In addition to this, the tests also reflect the vast experience and expertise of ebm-papst.



Vibration test

Vibration tests are carried out in compliance with

- Vibration test in operation according to DIN IEC 68, parts 2-6
- Vibration test at standstill according to DIN IEC 68, parts 2-6

Shock load

Shock load tests are carried out in compliance with

- Shock load according to DIN IEC 68, parts 2-27

Balancing quality

Testing the balancing quality is carried out in compliance with

- Residual imbalance according to DIN ISO 1940
- Standard balancing quality level G 6.3

Should you require a higher balancing quality level for your specific application, please let us know and specify this when ordering your product.

Chemo-physical strain / performance parameters

Should you have questions about chemo-physical strain, please direct them to your ebm-papst contact.

Fields of application, industries and applications

Our products are used in various industries and applications:

Ventilation, air-conditioning and refrigeration technology, clean room technology, automotive and rail technology, medical and laboratory technology, electronics, computer and office technology, telecommunications, household appliances, heating, machines and plants, drive engineering. Our products are not designed for use in the aviation and aerospace industry!

Legal and normative directives

The products described in this catalogue are designed, developed and produced in keeping with the standards in place for the relevant product and, if known, the conditions governing the relevant fields of application.

Standards

Information on standards is provided in the product-specific data sheets.

EMC

Information on EMC standards is provided in the product-specific data sheets.

Complying with the EMC standards has to be established on the final appliance, as different mounting situations can result in changed EMC properties.

Leakage current

Information on the leakage current is provided in the product-specific data sheets.

Measuring is according to IEC 60990.

Approvals

In case you require a specific approval for your ebm-papst product (VDE, UL, GOST, CCC, CSA, etc.) please let us know.

Most of our products can be supplied with the relevant approval.

Information on existing approvals is provided in the product-specific data sheets.

Air performance measurements

All air performance measurements are carried out on suction side and on chamber test beds conforming to the specifications as per ISO 5801 and DIN 24163. The fans under test are installed in the measuring chamber at free air intake and exhaust (installation category A) and are operated at nominal voltage, with AC also at nominal frequency, and without any additional components such as guard grilles.

As required by the standard, the air performance curves correspond to an air density of 1.2 kg/m³.

Technical parameters & scope



Measurement conditions for air and noise measurement

ebm-papst products are measured under the following conditions:

- Axial and diagonal fans in direction of rotation “V” in full nozzle and without guard grille
- Backward curved centrifugal fans, free-running and with inlet nozzle
- Forward curved single and dual inlet centrifugal fans with housing

Noise measurements

All noise measurements are carried out in low-reflective test rooms with reverberant floor. Thus the ebm-papst acoustic test chambers meet the requirements of precision class 1 according to DIN EN ISO 3745. For noise measurement, the fans being tested are placed in a reverberant wall and operated at nominal voltage (for AC, also at nominal frequency) without additional attachments such as the guard grille.

Sound pressure level and sound level

All acoustic values are established according to ISO 13347, DIN 45635 and ISO 3744/3745 to accuracy class 2 and given in A-rated form.

When the sound pressure level (L_p) is measured, the microphone is on the intake side of the fan being tested, usually at a distance of 1 m on the fan axis.

To measure the sound power level (L_w), 10 microphones are distributed over an enveloping surface on the intake side of the fan being tested (see graphic). The sound power level measured can be roughly calculated from the sound pressure level by adding 7 dB.

Measuring configuration as per ISO 13347-3 respectively DIN 45635-38:

- 10 measuring points

$$d \geq D$$

$$h = 1,5d \dots 4,5d$$

$$\text{Measurement area } S = 6d^2 + 7d(h + 1,5d)$$

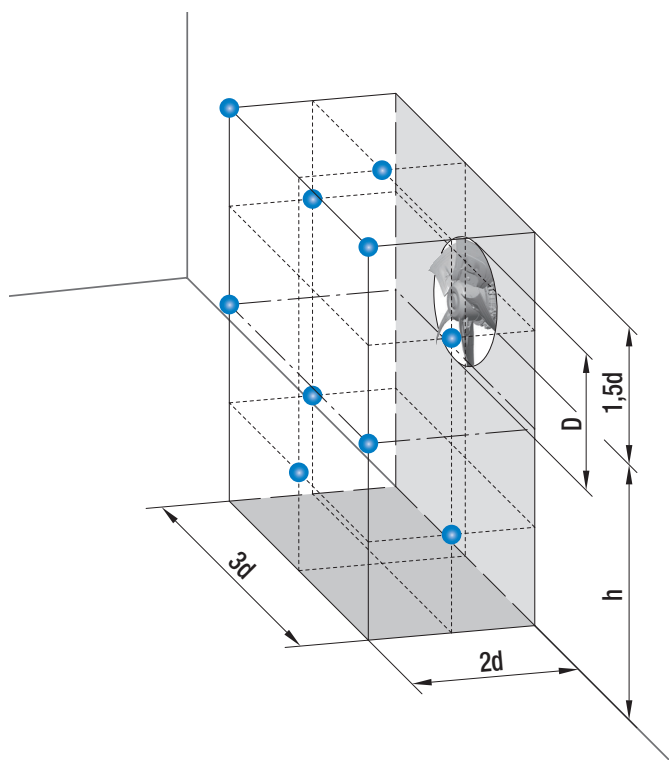



Combined level of multiple same-level sound sources

Adding 2 noise sources with the same level results in a level increase of approx. 3 dB.

The noise characteristics of multiple identical fans can be determined in advance based on the noise values specified in the data sheet. This is shown in the diagram opposite.

Example: 8 A3G800 axial fans are on a condenser. According to the data sheet, the sound pressure level of a fan is approximately 75 dB(A). The level increase measured from the diagram is 9 dB. Thus the overall sound level of the installation can be expected to be 84 dB(A).

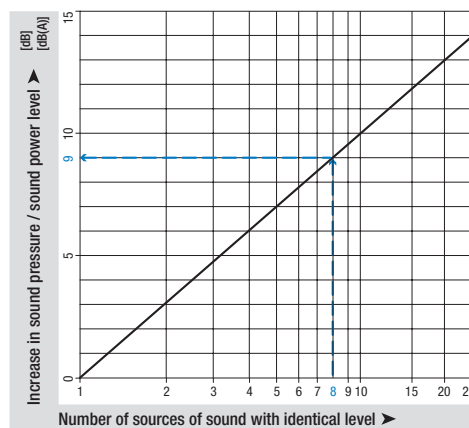

Combined level of two different-level sound sources

The acoustic performance of two different fans can be predetermined based on the sound levels given in the data sheet. This is shown in the diagram opposite.

Example: There is an axial fan A3G800 with a sound pressure level of 75 dB(A) at the operating point and an axial fan A3G710 with 71 dB(A) in a ventilation unit. The level difference is 4 dB.

The level increase can now be read in the diagram as approx. 1.5 dB. This means that the overall sound level of the unit can be expected to be 76.5 dB(A).

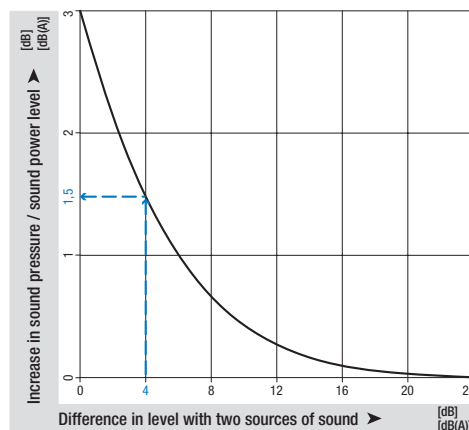

Distance laws

Sound power level is independent of distance to the sound source. In contrast to this, sound pressure level decreases the further away the noise source is. The adjacent diagram shows the decrease in level under far sound field conditions. Far sound field conditions apply whenever the distance between microphone and fan is big when compared to fan diameter and wavelength to be considered. For more information on far sound field, please consult the relevant literature on this complex topic. Per doubling of distance, the level in the far sound field decreases by 6 dB. In the near field of the fan, other correlations apply and the decrease in levels can be considerably smaller. The following example only applies to far sound field conditions and can vary strongly depending on the installation effects:

With an axial fan A3G300, a sound pressure level of 65 dB(A) was measured at a distance of 1 m. According to the adjacent diagram, at a distance of 20 m we would get a reduction by 26 dB, i.e. a sound pressure level of 39 dB(A).

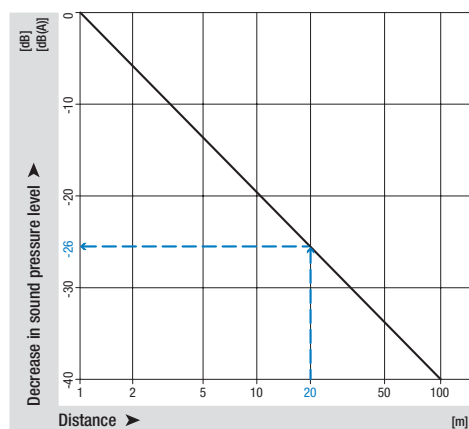

ebm-papst in Germany

ebm-papst Mulfingen GmbH & Co. KG

Bachmühle 2
74673 Mulfingen
GERMANY
Phone +49 7938 81-0
Fax +49 7938 81-110
info1@de.ebmpapst.com

ebm-papst St. Georgen GmbH & Co. KG

Hermann-Papst-Straße 1
78112 St. Georgen
GERMANY
Phone +49 7724 81-0
Fax +49 7724 81-1309
info2@de.ebmpapst.com

ebm-papst Landshut GmbH

Hofmark-Aich-Straße 25
84030 Landshut
GERMANY
Phone +49 871 707-0
Fax +49 871 707-465
info3@de.ebmpapst.com

ebm-papst Zeitlauf GmbH & Co. KG

Industriestraße 9
91207 Lauf a. d. Pegnitz
GERMANY
Phone +49 9123 945-0
Fax +49 9123 945-145
www.zeitlauf.com



Berlin

Dipl.-Ing. (TH) Jens Duchow
Händelstraße 7
16341 Panketal
GERMANY
Phone +49 30 944149-62
Fax +49 30 944149-63
Jens.Duchow@de.ebmpapst.com



Bielefeld

Dipl.-Ing. (FH) Wolf-Jürgen Weber
Niehausweg 13
33739 Bielefeld
GERMANY
Phone +49 5206 91732-31
Fax +49 5206 91732-35
Wolf-Juergen.Weber@de.ebmpapst.com



Dortmund

Dipl.-Ing. (FH) Hans-Joachim Pundt
Auf den Steinern 3
59519 Möhnese-Völlinghausen
GERMANY
Phone +49 2925 800-407
Fax +49 2925 800-408
Hans-Joachim.Pundt@de.ebmpapst.com



Frankfurt

Dipl.-Ing. Christian Kleffmann
Dr.-Hermann-Krause-Straße 23
63452 Hanau
GERMANY
Phone +49 6181 1898-12
Fax +49 6181 1898-13
Christian.Kleffmann@de.ebmpapst.com



Halle

Dipl.-Ing. (TU) Michael Hanning
Lercheneck 4
06198 Salztal / OT Lieskau
GERMANY
Phone +49 345 55124-56
Fax +49 345 55124-57
Michael.Hanning@de.ebmpapst.com



Hamburg

Ingenieurbüro Breuell GmbH
Ing. Dirk Kahl
Elektroingenieur
Grützmühlenweg 48
22339 Hamburg
GERMANY
Phone +49 40 538092-19
Fax +49 40 538092-84
Dirk.Kahl@de.ebmpapst.com



Heilbronn / Heidelberg

Dipl.-Ing. Mark Gartner
Gehweg 12
74199 Unterheinriet
GERMANY
Phone +49 7130 404569-1
Fax +49 7130 404569-2
Mark.Gartner@de.ebmpapst.com



Kassel

Dipl.-Ing. (FH) Ralph Brück
Hoherainstraße 3 b
35075 Gladenbach
GERMANY
Phone +49 6462 4071-10
Fax +49 6462 4071-11
Ralph.Brueck@de.ebmpapst.com



Koblenz

Winfried Schaefer
Hinter der Kirch 10
56767 Uersfeld
GERMANY
Phone +49 2657 16-96
Fax +49 2657 16-76
Winfried.Schaefer@de.ebmpapst.com



Munich

Dipl.-Wirt.-Ing. (FH) Jens Peter
Landsbergerstraße 14
86932 Pürgen
GERMANY
Phone +49 8196 99877-54
Fax +49 8196 99877-55
Jens.Peter@de.ebmpapst.com



Nuremberg

Dipl.-Wirt.-Ing. (FH) Axel Resch
Dr.-August-Koch-Str. 1
91639 Wolfraams-Eschenbach
GERMANY
Phone +49 9875 9783-170
Fax +49 9875 9783-171
Axel.Resch@de.ebmpapst.com



Offenburg

Dipl.-Ing. (FH) Ralf Braun
Hubeneck 21
77704 Oberkirch
GERMANY
Phone +49 7802 9822-52
Fax +49 7802 9822-53
Ralf.Braun@de.ebmpapst.com



Stuttgart

Dipl.-Ing. (FH) Rudi Weinmann
Hindenburgstraße 100/1
73207 Plochingen
GERMANY
Phone +49 7153 9289-80
Fax +49 7153 9289-81
Rudi.Weinmann@de.ebmpapst.com



Ulm

M.Sc. Reinhard Sommerreißer
Am Silbermannpark 10
86161 Augsburg
GERMANY
Phone +49 821 6610-7023
Fax +49 821 6610-7024
Reinhard.Sommerreisser@de.ebmpapst.com

Distributors



Frankfurt

R.E.D. Handelsgesellschaft mbH
Gutenbergstraße 3
63110 Rodgau - Jügesheim
GERMANY
Phone +49 6106 841-0
Fax +49 6106 841-111
info@red-elektromechanik.de
www.red-elektromechanik.de



Hamburg

Breuell + Hilgenfeldt GmbH
Grützmühlenweg 48
22339 Hamburg
GERMANY
Phone +49 40 538092-20
Fax +49 40 538092-84
info@breuell-hilgenfeldt.de



Munich

A. Schweiger GmbH
Ohmstraße 1
82054 Sauerlach
GERMANY
Phone +49 8104 897-0
Fax +49 8104 897-90
info@schweiger-gmbh.de
www.schweiger-gmbh.com

● **Express Service-Center** (1 to 5 pieces)



North

Breuell + Hilgenfeldt GmbH
Grützmühlenweg 48
22339 Hamburg
GERMANY
Phone +49 40 538092-20
Fax +49 40 538092-84
info@breuell-hilgenfeldt.de



South

HDS Ventilatoren Vertriebs GmbH
Glaswiesenstraße 1
74677 Dörzbach
GERMANY
Phone +49 7937 80355-20
Fax +49 7937 80355-25
info@hds-gmbh.net
www.hds-gmbh.net

ebm-papst in Europe

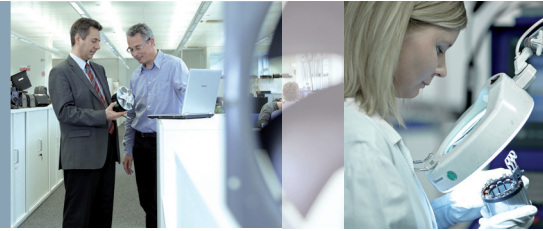

Europe



Austria

ebm-papst Motoren & Ventilatoren GmbH
Straubingstraße 17
4030 Linz
AUSTRIA
Phone +43 732 321150-0
Fax +43 732 321150-20
info@at.ebmpapst.com
www.ebmpapst.at



Belarus

ebm-papst Bel AgmbH
Lipkovskaya Gasse 34
Office No.6, Room 106,107
223010 Minsk
BELARUS
Phone +375 17 3851556
Fax +375 17 3851556
info@by.ebmpapst.com
www.ebmpapst.by



Belgium

ebm-papst Benelux B.V.
Sales office Belgium-Luxemburg
Romeinsestraat 6/0101
Research Park Haasrode
3001 Heverlee-Leuven
BELGIUM
Phone +32 16 396-200
Fax +32 16 396-220
info@be.ebmpapst.com
www.ebmpapst.be



Bulgaria

ebm-papst Romania S.R.L.
Str. Tarnavei No. 20
500327 Brasov
ROMANIA
Phone +40 268 331859
Fax +40 268 312805
dudasludovic@xnet.ro



Croatia

ebm-papst Industries Kft.
Ezred u. 2.
1044 Budapest
HUNGARY
Phone +36 1 8722-190
Fax +36 1 8722-194
office@hu.ebmpapst.com



Czech Republic / Slovakia

ebm-papst CZ s.r.o.
Kaštanová 34a
620 00 Brno
CZECH REPUBLIC
Phone +420 544 502-411
Fax +420 547 232-622
info@ebmpapst.cz
www.ebmpapst.cz



Denmark

ebm-papst Denmark ApS
Vallensbækvej 21
2605 Brøndby
DENMARK
Phone +45 43 631111
Fax +45 43 630505
mail@dk.ebmpapst.com
www.ebmpapst.dk



Estonia

ebm-papst Oy, Eesti Filiaal
Kesk tee 13
Aaviku küla, Jüri Tehnopark
75301 Rae Vald, Harjumaa
ESTONIA
Phone +372 65569-78
Fax +372 65569-79
www.ebmpapst.ee



Finland

ebm-papst Oy
Puistotie 1
02760 Espoo
FINLAND
Phone +358 9 887022-0
Fax +358 9 887022-13
mailbox@ebmpapst.fi
www.ebmpapst.fi



France

ebm-papst sarl
ZI Nord - rue A. Mohler
BP 62
67212 Obernai Cedex
FRANCE
Phone +33 820 326266
Fax +33 3 88673883
info@ebmpapst.fr
www.ebmpapst.fr



Greece

Helcoma
Th. Rotas & Co OE
Davaki 65
17672 Kallithea-Attiki
GREECE
Phone +30 210 9513-705
Fax +30 210 9513-490
contact@helcoma.gr
www.helcoma.gr



Hungary

ebm-papst Industries Kft.
Ezred u. 2.
1044 Budapest
HUNGARY
Phone +36 1 8722-190
Fax +36 1 8722-194
office@hu.ebmpapst.com



Iceland

RJ Engineers
Stangarhyl 1a
110 Reykjavik
ICELAND
Phone +354 567 8030
Fax +354 567 8015
rj@rj.is
www.rj.is



Ireland

ebm-papst UK Ltd.
Chelmsford Business Park
Chelmsford Essex CM2 5EZ
UNITED KINGDOM
Phone +44 1245 468555
Fax +44 1245 466336
sales@uk.ebmpapst.com
www.ebmpapst.co.uk



AuBren Limited

Portlaoise Business & Technology Park
Mountrath Road
Portlaoise, Co. Laois
IRELAND
Phone +353 57 8664343
Fax +353 57 8664346
sales@ie.aubren.com
www.aubren.com



Italy

ebm-papst Srl
Via Cornaggia 108
22076 Mozzate (Co)
ITALY
Phone +39 0331 836201
Fax +39 0331 821510
info@it.ebmpapst.com
www.ebmpapst.it



Macedonia

ebm-papst Industries Kft.
Ezred u. 2.
1044 Budapest
HUNGARY
Phone +36 1 8722-190
Fax +36 1 8722-194
office@hu.ebmpapst.com

ebm-papst in Europe



Netherlands
ebm-papst Benelux B.V.
Engelseweg 127
5705 AC Helmond
NETHERLANDS
Phone +31 492 502-900
Fax +31 492 502-950
verkoop@nl.ebmpapst.com
www.ebmpapst.nl

Norway
ebm-papst AS
P.B. 173 Holmlia
1203 Oslo
NORWAY
Phone +47 22 763340
Fax +47 22 619173
mailbox@ebmpapst.no
www.ebmpapst.no

Poland
ebm-papst Polska Sp. z o.o.
ul. Annopol 4A
03236 Warszawa
POLAND
Phone +48 22 6757819
Fax +48 22 6769587
office@ebmpapst.pl
www.ebmpapst.pl

Portugal
ebm-papst (Portugal), Lda.
Centro Empresarial de Alverca
Rua de Adarse, Vale D'Ervas
Corpo D / Fracção 3
2615-178 Alverca do Ribatejo
PORTUGAL
Phone +351 218 394 880
Fax +351 218 394 759
info@pt.ebmpapst.com
www.ebmpapst.pt

Romania
ebm-papst Romania S.R.L.
Str. Tarnavei Nr. 20
500327 Brasov
ROMANIA
Phone +40 268 331859
Fax +40 268 312805
dudasludovic@xnet.ro

Russia
ebm-papst Ural GmbH
Posadskaja-Strasse, 23(E), 3
620102 Ekaterinburg
RUSSIA
Phone +7 343 2338000
Fax +7 343 2337788
Konstantin.Molokov@ru.ebmpapst.com
www.ebmpapst.ur.ru

ebm-papst Rus GmbH
proezd 4529, vladenie 5, stroenie 1
141000 Mytistschi, Oblast Moskau
RUSSIA
Phone +7 495 9807524
Fax +7 495 5140924
info@ebmpapst.ru
www.ebmpapst.ru



Serbia & Montenegro
ebm-papst Industries Kft.
Ezred u. 2.
1044 Budapest
HUNGARY
Phone +36 1 8722-190
Fax +36 1 8722-194
office@hu.ebmpapst.com

Spain
ebm-papst Ibérica S.L.
Avda. del Sistema Solar, 29
28830 San Fernando de Henares (Madrid)
SPAIN
Phone +34 91 6780894
Fax +34 91 6781530
ventas@ebmpapst.es
www.ebmpapst.es

Sweden
ebm-papst AB
Äggelundavägen 2
17562 Järfälla
SWEDEN
Phone +46 10 4544400
Fax +46 8 362306
info@ebmpapst.se
www.ebmpapst.se

Switzerland
ebm-papst AG
Rütisbergstrasse 1
8156 Oberhasli
SWITZERLAND
Phone +41 44 73220-70
Fax +41 44 73220-77
verkauf@ebmpapst.ch
www.ebmpapst.ch

Turkey
Akantel Elektronik San. Tic. LTD. Sti.
Atatürk Organize Sanayi
Bölgesi 10007 SK. No.:6
35620 Cigli-Izmir
TURKEY
Phone +90 232 3282090
Fax +90 232 3280270
akantel@akantel.com.tr
www.ebmpapst.com.tr

Ukraine
ebm-papst Ukraine LLC
Lepse Boulevard, 4, Building 21
03067 Kiev
UKRAINE
Phone +38 044 2063091
Fax +38 044 2063091
mail@ebmpapst.ua
www.ebmpapst.ua

United Kingdom
ebm-papst UK Ltd.
Chelmsford Business Park
Chelmsford Essex CM2 5EZ
UNITED KINGDOM
Phone +44 1245 468555
Fax +44 1245 466336
sales@uk.ebmpapst.com
www.ebmpapst.co.uk

ebm-papst Automotive & Drives (UK) Ltd.
The Smithy
Fidlers Lane
East Ilsley, Berkshire RG20 7LG
UNITED KINGDOM
Phone +44 1635 2811-11
Fax +44 1635 2811-61
A&Dsales@uk.ebmpapst.com
www.ebmpapst-ad.com

ebm-papst in America and Africa

America

 **Argentina**
 ebm-papst de Argentina S.A.
Hernandarias 148 Lomas del Mirador
Pcia. de Buenos Aires (1752)
ARGENTINA
Phone +54 11 46576135
Fax +54 11 46572092
ventas@ar.ebmpapst.com
www.ebmpapst.com.ar

 **Brasil**
 ebm-papst Motores Ventiladores Ltda.
Av. José Giorgi, 301 Galpões B6+B7
Condominio Logical Center
06707-100 Cotia - São Paulo
BRAZIL
Phone +55 11 4613-8700
Fax +55 11 4777-1456
vendas@br.ebmpapst.com
www.ebmpapst.com.br

 **Canada**
 ebm-papst Canada Inc.
1800 Ironstone Manor, Unit 2
Pickering, Ontario, L1W3J9
CANADA
Phone +1 905 420-3533
Fax +1 905 420-3772
sales@ca.ebmpapst.com
www.ebmpapst.ca

 **Mexico**
 ebm Industrial S. de R.L. de C.V.
Paseo de Tamarindos 400-A-5to Piso
Col. Bosques de las Lomas
Mexico 05120, D.F.
MEXICO
Phone +52 55 3300-5144
Fax +52 55 3300-5243
sales@mx.ebmpapst.com
www.ebmpapst.com.mx

USA

 ebm-papst Inc.
 P.O. Box 4009
100 Hyde Road
Farmington, CT 06034
UNITED STATES
Phone +1 860 674-1515
Fax +1 860 674-8536
sales@us.ebmpapst.com
www.ebmpapst.us

 ebm-papst Automotive & Drives, Inc.
 3200 Greenfield, Suite 255
Dearborn, MI 48120
UNITED STATES
Phone +1 313 406-8080
Fax +1 313 406-8081
automotive@us.ebmpapst.com
www.ebmpapst-automotive.us

Africa

 **South Africa**
 ebm-papst South Africa (Pty) Ltd.
P.O. Box 3124
1119 Yacht Avenue
2040 Honeydew
SOUTH AFRICA
Phone +27 11 794-3434
Fax +27 11 794-5020
info@za.ebmpapst.com
www.ebmpapst.co.za



ebm-papst in Asia and Australia



Asia

China

  
ebm-papst Ventilator (Shanghai) Co., Ltd.
No. 418, Huajing Road
WaiGaoQiao Free Trade Zone
No. 2001, Yang Gao (N) Road
200131 Shanghai
P.R. of CHINA
Phone +86 21 5046-0183
Fax +86 21 5046-1119
sales@cn.ebmpapst.com
www.ebmpapst.com.cn

Hong Kong

  
ebm-papst Hong Kong Ltd.
Room 17E, MG Tower
133 Hoi Bun Road, Kwun Tong
Hong Kong
P.R. of CHINA
Phone +852 2145-8678
Fax +852 2145-7678
info@hk.ebmpapst.com

India

  
ebm-papst India Pvt. Ltd.
26/3, G.N.T. Road, Erukkencherry
Chennai-600118
INDIA
Phone +91 44 25372556
Fax +91 44 25371149
sales@in.ebmpapst.com
www.ebmpapst.in

Indonesia

  
ebm-papst Indonesia
Representative Office
German Centre, 4th Floor, Suite 4470
Jl. Kapt. Subijono Dj. Bumi Serpong Damai
15321 Tangerang
INDONESIA
Phone +62 21 5376250
Fax +62 21 5388305
salesdept@id.ebmpapst.com

Israel

  
Polak Bros. Import Agencies Ltd.
9 Hamefalsim Street
Kiryat Arie, Petach-Tikva 49514
ISRAEL
Phone +972 3 9100300
Fax +972 3 5796679
polak@polak.co.il
www.polak.co.il

Japan

  
ebm-papst Japan K.K.
12th Floor, Benex S-3 Bldg.
3-20-8 Shinyokohama, Kohoku-ku
222-0033 Yokohama
JAPAN
Phone +81 45 47057-51
Fax +81 45 47057-52
info@jp.ebmpapst.com
www.ebmpapst.jp

Korea

  
ebm-papst Korea Co. Ltd.
6F, Trutech Bldg.
12, WorldCupbuk-ro 56-gil
Mapo-Gu
Seoul 121-835
KOREA
Phone +82 2 366213-24
Fax +82 2 366213-26
info@kr.ebmpapst.com
www.ebmpapst.co.kr

Malaysia

  
ebm-papst Malaysia
Representative Office
Unit 12-2, Jalan USJ Sentral 3
Persiaran Subang, Selangor Darul Ehsan
47600 Subang Jaya
MALAYSIA
Phone +60 3 8024-1680
Fax +60 3 8024-8718
salesdept@my.ebmpapst.com

Singapore

  
ebm-papst SEA Pte. Ltd.
No. 23 Ubi Road 4
#06-00 Olympia Industrial Building
Singapore 408620
SINGAPORE
Phone +65 65513789
Fax +65 68428439
salesdept@sg.ebmpapst.com

Taiwan

  
ETECO Engineering & Trading Corp.
10F-I, No. 92, Teh-Wei Str.
Tsow-Inn District, Kaohsiung
TAIWAN
Phone +886 7 557-4268
Fax +886 7 557-2788
eteco@ms22.hinet.net
www.ebmpapst.com.tw

Thailand

  
ebm-papst Thailand Co., Ltd.
99/9 Moo 2, Central Chaengwattana Tower
14th Floor, Room 1402
Chaengwattana Road Bangtarad, Pakkret
11120 Nonthaburi
THAILAND
Phone +66 2 8353785-7
Fax +66 2 8353788
salesdept@th.ebmpapst.com

United Arab Emirates

  
ebm-papst Middle East FZE
PO Box 17755
Jebel Ali Free Zone / FZS1 / AP05
Dubai
UNITED ARAB EMIRATES
Phone +971 4 88608-26
Fax +971 4 88608-27
info@ae.ebmpapst.com
www.ebmpapst.ae

Vietnam

  
ebm-papst Vietnam
Representative Office
Room #102, 25 Nguyen Van Thu Street
District 1
Ho Chi Minh City
VIETNAM
Phone +84 8 39104099
Fax +84 8 39103970
linh.nguyen@vn.ebmpapst.com

Australia

Australia

  
ebm-papst A&NZ Pty Ltd.
10 Oxford Road
Laverton North, Victoria, 3026
AUSTRALIA
Phone +61 3 9360-6400
Fax +61 3 9360-6464
sales@ebmpapst.com.au
www.ebmpapst.com.au

New Zealand

  
ebm-papst A&NZ Pty Ltd.
61 Hugo Johnston Drive, Unit H
Penrose 1061, Auckland
NEW ZEALAND
PO Box 112278,
Penrose 1642, Auckland
Phone +64 9 525-0245
Fax +64 9 525-0246
sales@ebmpapst.com.au
www.ebmpapst.com.au



Notes

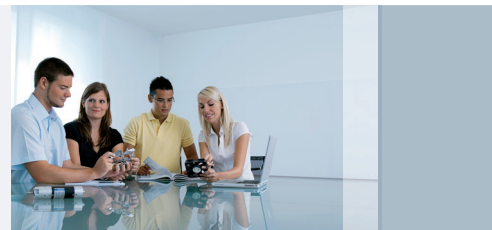



ebm-papst
Mulfingen GmbH & Co. KG

Bachmühle 2
74673 Mulfingen
Germany
Phone +49 7938 81-0
Fax +49 7938 81-110
info1@de.ebmpapst.com

ebm-papst
St. Georgen GmbH & Co. KG

Hermann-Papst-Straße 1
78112 St. Georgen
Germany
Phone +49 7724 81-0
Fax +49 7724 81-1309
info2@de.ebmpapst.com

ebm-papst
Landshut GmbH

Hofmark-Eich-Straße 25
84030 Landshut
Germany
Phone +49 871 707-0
Fax +49 871 707-465
info3@de.ebmpapst.com

ebmpapst

The engineer's choice